

DEPARTMENT OF THE ARMY TECHNICAL MANUAL

INSPECTION, CARE AND
MAINTENANCE OF

ANTIFRICTION
BEARINGS

HEADQUARTERS, DEPARTMENT OF THE ARMY
NOVEMBER 1959

TECHNICAL MANUAL }
No. 9-214

HEADQUARTERS
DEPARTMENT OF THE ARMY
WASHINGTON 25, D.C., 19 November 1959

INSPECTION, CARE, AND MAINTENANCE OF ANTIFRICTION BEARINGS

		Paragraph	Page
SECTION I.	INTRODUCTION.....	1, 2	2
II.	DESCRIPTION OF ANTIFRICTION BEARINGS.....	3-8	3-10
III.	BEARING REMOVAL.....	9-14	14-27
IV.	CLEANING, DRYING, AND DEMAGNETIZING BEARINGS.....	15-20	30-34
V.	INSPECTION AND SERVICEABILITY STANDARDS OF BEARINGS.....	21-24	35-40
VI.	BEARING INSTALLATION.....	25-31	41-49
VII.	BEARING ADJUSTMENT.....	32-45	53-61
VIII.	LUBRICATION OF BEARINGS.....	46-51	69-70
IX.	AUXILIARY EQUIPMENT.....	52-57	76-77
X.	MARKING, STORAGE, AND SHIPMENT OF NEW BEARINGS.....	58-61	78-79
APPENDIX	REFERENCES.....		80
	INDEX.....		82

COPYRIGHT NOTICE: Copyrighted material contained herein is reprinted by permission of The General Motors Corporation, Harrison, New Jersey; Timken Roller Bearing Company. Canton, Ohio; and The Torrington Company, Torrington, Connecticut.

*This manual supersedes TM 1-5-1-11, 20 April 1954; TM 37-265, 31 January) 1945; TB 37-265-1, 15 September 1949; TB ORD 438, 26 June 1952; TB ORD 582, 24 September 1954; anti TB ENG 11, 6 March 1944.

Section I

INTRODUCTION

1. Scope

a. The purpose of this manual is to provide instructions for procedures in the inspection, care, and maintenance of antifriction bearings, which are identified under Federal Supply Classification Group 31 of the Federal Cataloging Program.

b. One of the chief objectives is to impress upon maintenance personnel the necessity for extreme care in handling bearings. Such care is necessary because of the closeness of the tolerances to which antifriction bearing components and assemblies are held in manufacture. Observance of the rules and recommendations set forth herein should result in satisfactory bearing performance.

c. The instructions contained herein include the description, removal, cleaning, inspection, installation, adjustment, lubrication, care, handling, packing, and Storage of antifriction bearings, associated parts, and subassemblies. All identification numbers given are Federal stock numbers.

d. The methods and procedures established in this manual will govern in cases where conflict may arise with previously published information, except as noted by reference to publications pertaining to a particular type of equipment.

e. The appendix contains a list of current references, including supply manuals, forms, technical manuals, and other available publications applicable to bearings.

f. Any errors or omissions will be brought to the attention of the Commanding Officer, Raritan Arsenal, Metuchen, N. J., ATTN: ORDJR-OPRA, using DA Form 2028.

2. Forms, Records, and Reports

a. *General.* Responsibility for the proper execution of forms, records, and reports rests upon the officers of all units maintaining this equipment. However, the value of accurate records must be fully appreciated by all persons responsible for their compilation, maintenance, and use. Records, reports, and authorized forms are normally utilized to indicate the type, quantity, and condition of materiel to be inspected, to be repaired, or to be used in repair. Properly executed forms convey authorization and serve as records for repair or replacement of materiel in the hands of troops and for delivery of materiel requiring further repair to ordnance shops in arsenals, depots, etc. The forms, records, and reports establish the work required, the progress of the work within the shops, and the status of the materiel upon completion of its repair.

b. *Authorized Forms.* The forms generally applicable to units maintaining this materiel are listed in the appendix. For a listing of all forms, refer to DA Pam 310-2. For instructions on use of these forms, refer to FM 9-10.

c. *Field Reports of Accidents.* The reports necessary to comply with the requirements of the Army program are prescribed in detail in AR 385-40. These reports are required whenever accidents involving injury to personnel or damage to materiel occur.

d. *Report of Unsatisfactory Equipment or Materials.* Any deficiencies detected in the equipment covered herein, which occur under the circumstances indicated in AR 700-38, should be immediately reported in accordance with the applicable instructions in cited regulation.

AGO 2737A

Section II

DESCRIPTION OF ANTIFRICTION BEARINGS

3. General

a. Antifriction (rolling contact) bearings (fig. 1) may be divided into five general types based on the shape or size of the rolling elements, which are ball, cylindrical roller, tapered roller, shaped roller (barrel or hourglass-

shaped, etc.), and needle roller. Each of these types embodies a particular feature or quality which lends itself to a particular installation but which may exclude it from other installations.

AGO 2787A

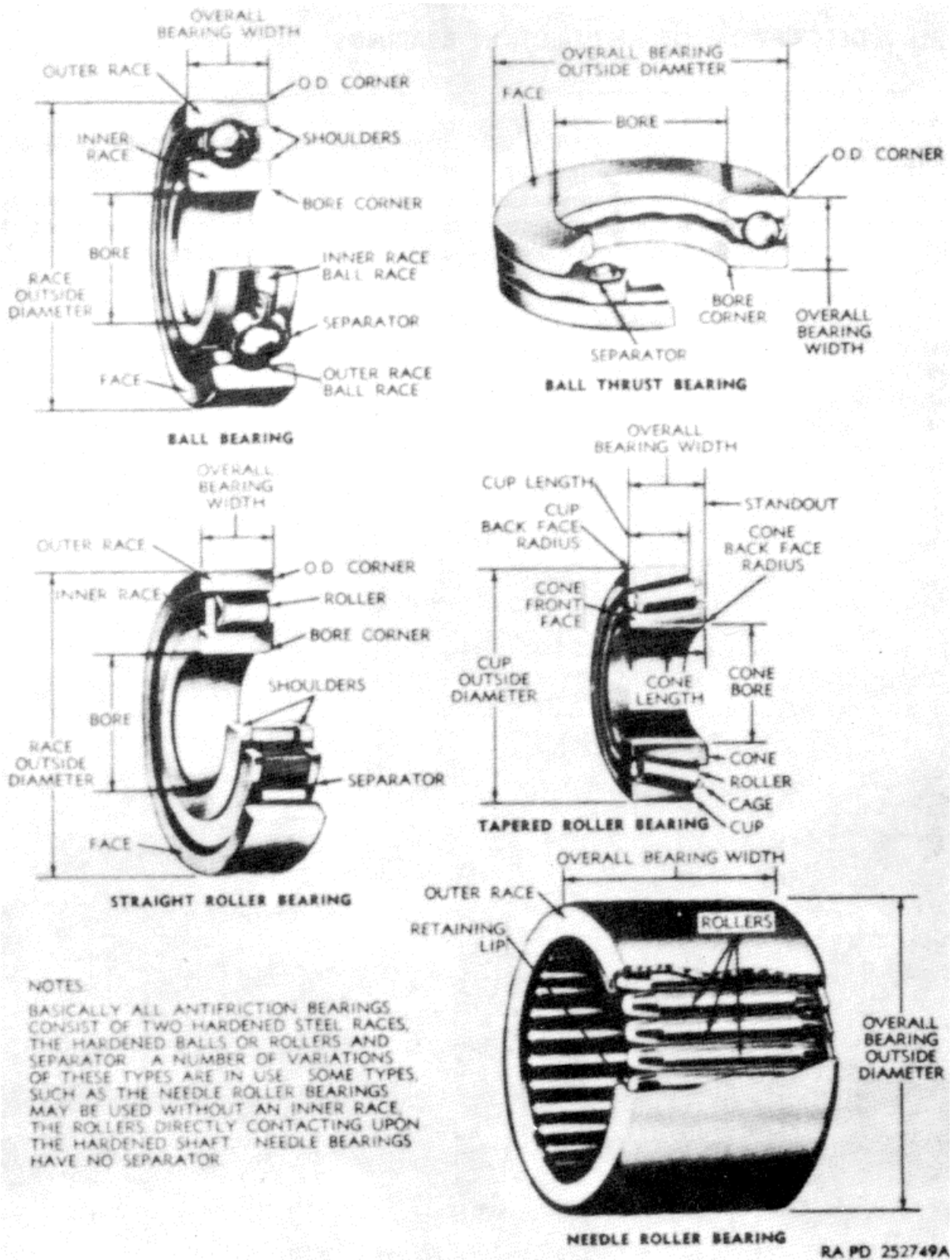

Figure 1. Antifriction bearing component parts.

b. In general, ball bearings which have a point contact between the rolling elements and the races are suitable for light loads and high speeds. Roller and needle roller bearings which have line contacts between rolling elements and races, though less efficient, are more suitable to heavy loads and slow speeds. However, ball bearings may be so designed that they will satisfactorily carry reasonably heavy loads and roller bearings may be designed to withstand reasonably high speeds.

c. The materials used and the workmanship employed in the manufacture of antifriction bearings should be of the finest quality. Each part or assembly is held to precision tolerances. Bearings should give satisfactory service, if properly selected, installed, and adequately maintained. Any abuse, rust, or dirt that causes the slightest abrasion or damage to the highly polished contacting surfaces may lead to spalling and premature failure. Care and cleanliness cannot be

overemphasized in the installation and maintenance of antifriction bearings.

d. It should be noted that dimensional interchangeability does not necessarily indicate functional interchangeability because bearings for different loads, speeds, and conditions have different internal construction and may fail if not of the design for the particular installation.

Every precaution should be taken to insure that replacement bearings are functionally interchangeable with the original bearings.

4. Ball Bearings

a. Ball bearing (fig. 2) construction such as size and number of balls, depth and type of groove, width and thickness of races, separators, etc., varies depending upon the load and speed for which the bearing was designed.

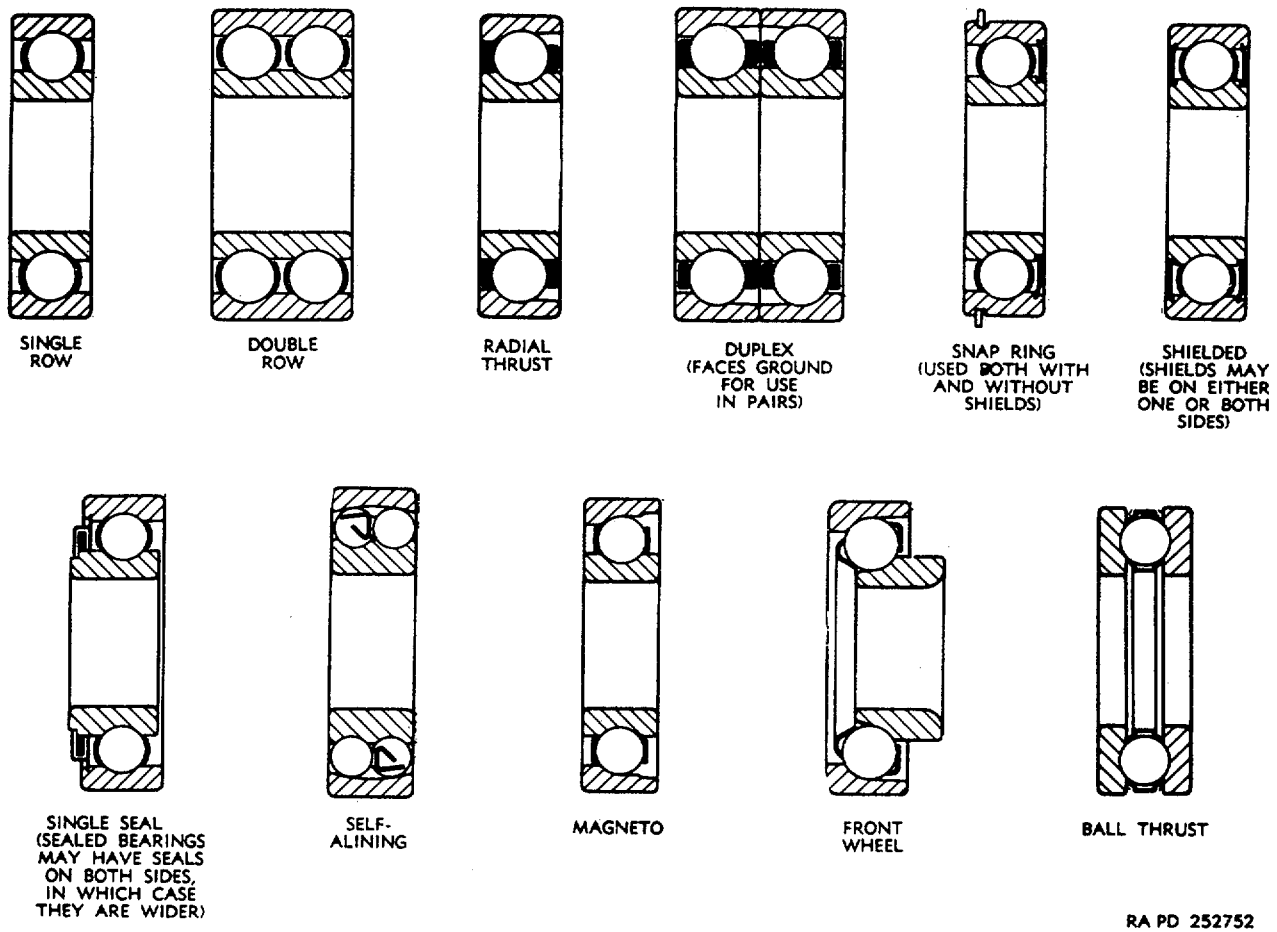

Figure 2. Types of ball bearings.

b. Where the ball bearing is to sustain extremely heavy loads at very slow speeds, a full row of balls without separators is occasionally used. The raceways of the inner and outer races have curvatures which conform closely to the curvature of the balls, so as to provide the maximum load carrying capacity. However, the raceway curvature is slightly greater than the ball curvature to reduce the friction between the balls and the sides of the raceway.

c. For increased radial load capacity at higher speeds, ball bearings are sometimes made with two rows of balls, each row having its own separator.

d. Another type of ball bearing is designed to compensate for misalignment of the shaft with the housing. This design features two deep raceways in the inner race, with the outer raceway of spherical form, the center of the sphere coinciding with the shaft axis. The outer race is therefore free to align itself as required, without binding the balls. The load-carrying capacity of such a bearing, however, is limited, due to the small contact area between the balls and the outer raceway.

e. Single-row radial ball bearings may be manufactured to carry heavier radial loads by using a filling notch for the introduction of the last three or four balls. Bearings manufactured in this manner will not carry as heavy a thrust load as bearings that do not employ a filling notch but which contain the maximum number and size balls that can be introduced by eccentric displacement of the races.

f. Certain bearings are made with an angular contact for light radial loads in combination with heavy single direction thrust loads which are not subject to reversal of direction. For extremely heavy thrust loads in a single direction, two or more of these bearings may be mounted with the small face of the outer races facing in the same direction as the thrust. These bearings may also be mounted with the small faces of the outer rings clamped together and are thus automatically preloaded. In this case, they are effective for radial loads in combination with thrust loads in either direction, particularly when the proportion of thrust to radial load is high. They may also be mounted with the outer race thrust faces abutting, however, this mounting is not desirable for heavy thrust loads.

g. In applications where there is no radial load, thrust ball bearings are employed. These consist of two plates or washers between which balls rotate. The

washers ordinarily have grooved raceways although flat ungrooved washers are sometimes employed for light loads. One washer is mounted so as to rotate with the shaft while the other is stationary. Separators made of machined brass or pressed steel are generally used to separate the balls. The speed at which thrust ball may be rotated is limited because of the centrifugal action which tends to force the balls outward, causing wedging.

h. The range of speed at which ball bearings rotate varies from an almost imperceptible movement, as in instrument gimbals, to speeds of 100,000 r.p.m. when used in small grinders.

In both extremes of speed, the highest degree of precision and smoothness of the raceways and balls is required.

i. For continuous high-speed operation, separators are frequently made of phenol-impregnated composition, accurately machined for good balance. This material is light in weight and requires little lubrication; it cannot be used at temperatures higher than 250° F.

j. For moderate speeds, steel separators formed in two halves and riveted together are satisfactory, and the majority of bearing separators are of this type. Separators are sometimes machined from bronze or aluminum tubing, the latter material being desirable where weight is a major consideration.

k. There are many other special features such as shields, seals, snap-rings, special races, etc., which are built into certain designs of ball bearings to adapt them to a particular installation, condition, load, or environment. In the installation, care, and maintenance of bearings, these features must be given due consideration and handling of the bearing modified to meet the particular special feature encountered. Care and cleanliness are always a must where bearings are involved.

5. Cylindrical Roller Bearings

a. *General.* Cylindrical roller bearings are designed principally to carry radial loads. For low speeds, cylindrical roller bearings having rollers of a length several times their diameter may be used but where speeds are higher, bearings having rollers of the same length as the diameter give the best results. When made with extreme

precision, such roller bearings may be operated at speeds which approach those obtainable with ball bearings.

b. Rollers. The rollers of cylindrical roller bearings are generally solid steel cylinders but may be formed of helically wound strips of alloy steel. In the latter case, the cage consists of two pressed steel end rings, rigidly held by spacing bars riveted in countersunk holes in the end rings.

c. Races. Cylindrical roller bearings may be made with separable inner races, separable outer races, separable inner and outer races, or with non-separable races. These features give these bearings an advantage in certain assembly and disassembly operations as explained in (1) through (3) below.

- (1) *Separable inner race bearing* (figs. 3 and 4). This class of bearing has the outer race, rollers, and separator permanently assembled as a unit, while the inner race

is separable. The outer race assembly and inner race are mounted in the housing and on the shaft in two separate operations. The inner race with the shaft can be removed from the equipment without disturbing the outer race assembly.

- (2) *Separable outer race bearing* (figs. 3 and 4). This class of bearing has the inner race, rollers, and separator permanently assembled as a unit, while the outer race is separable. The inner race assembly and outer race are mounted on the shaft and in the housing, respectively, in two different operations. When disassembling, it would be advisable to remove the inner race assembly and shaft from the equipment before removing the outer race.

AGO 2737A

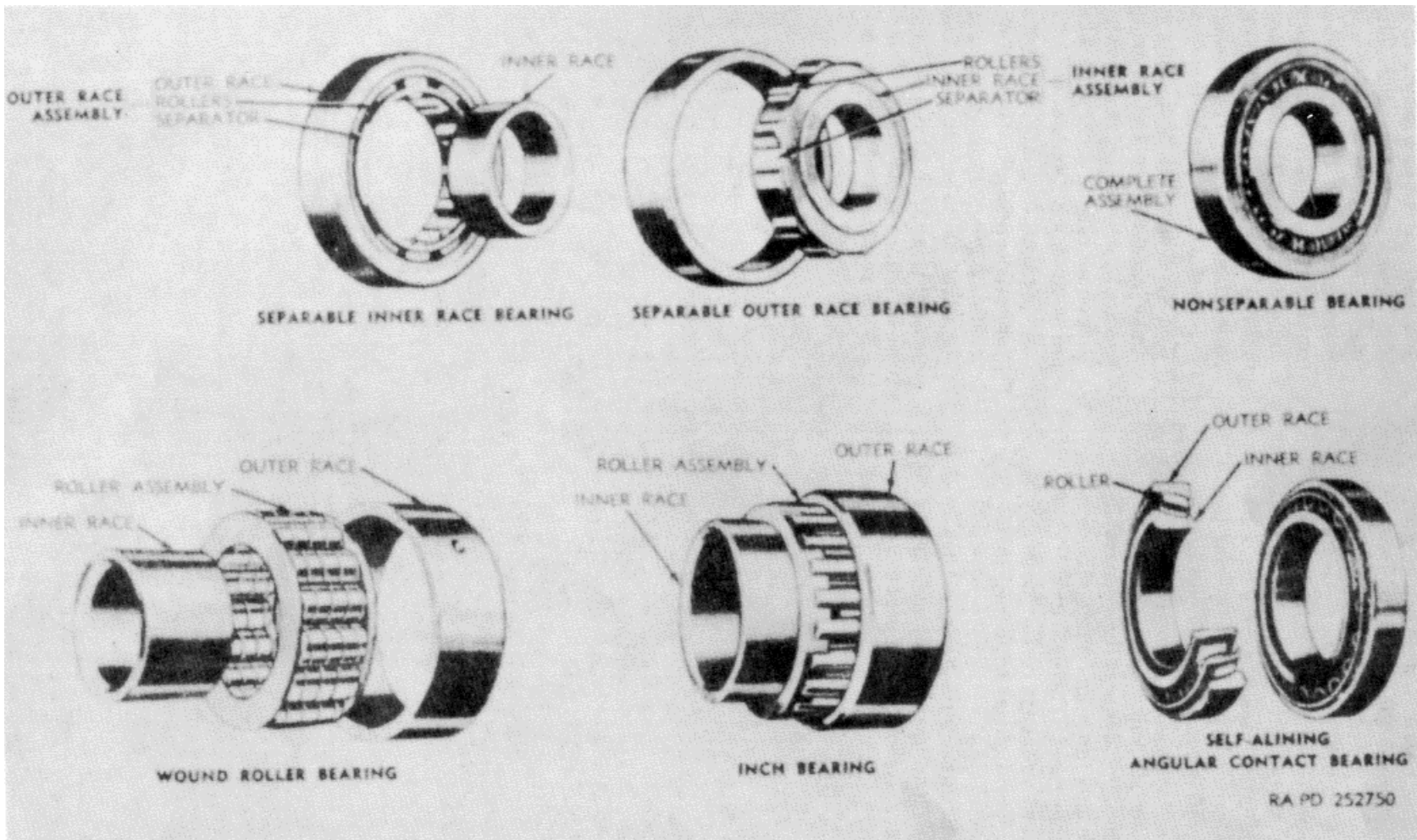
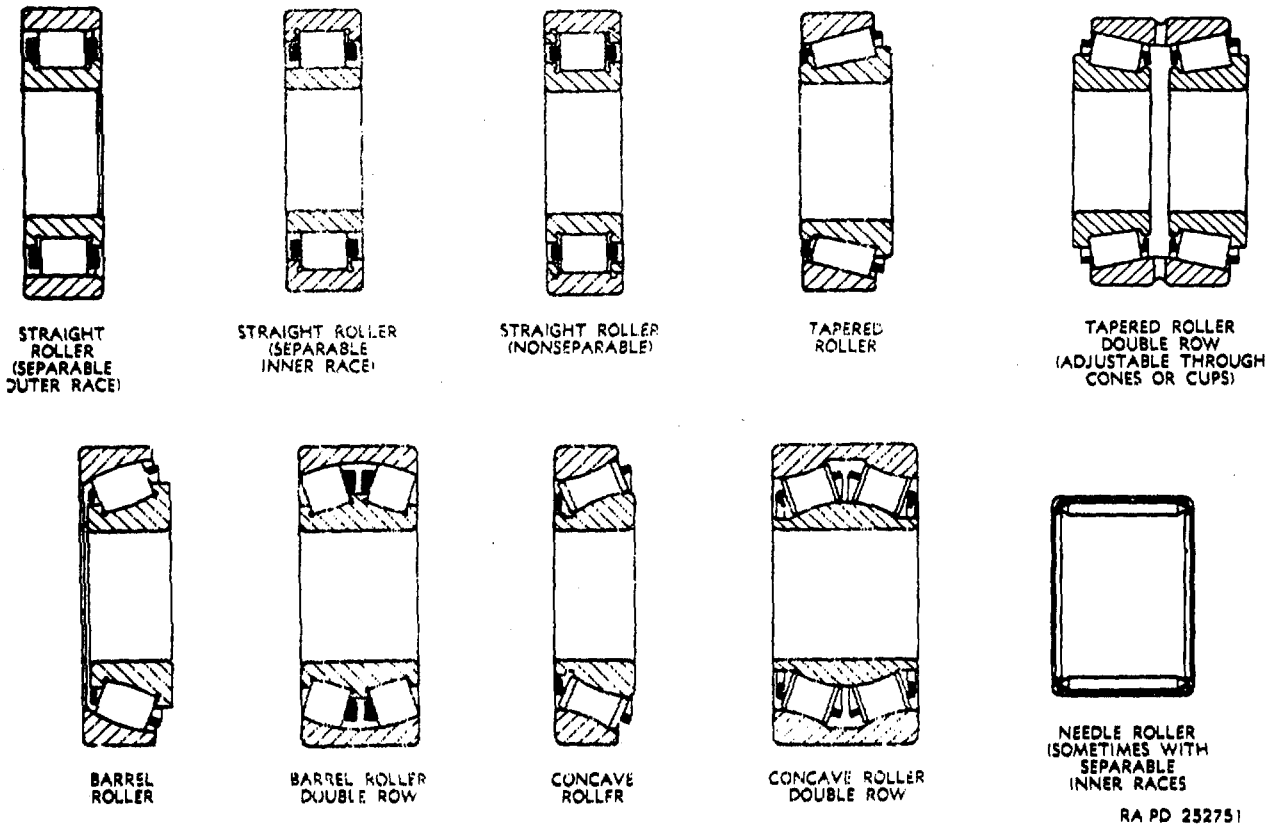

Figure 3. Classification of roller bearings.



RA PD 252751

Figure 4. Type of roller bearings.

- (3) *Nonseparable bearing* (figs. 3 and 4). In this class of bearing, the inner race, outer race, rollers, and separator are permanently combined into one unit. This class of bearing must be installed or removed from the equipment as a complete unit. The bearing is usually pressed on the shaft and the bearing and shaft are installed as a unit, or the bearing and shaft are removed as a unit. The bearing later is removed from the shaft with a press.
- (4) *Separable inner and outer races* (fig. 3). This class of bearing has the rollers and separators permanently assembled as a unit while both the inner and outer races are separable.

Note. In certain installations, either of the two races are sometimes eliminated by proper treatment of the corresponding mating part.

6. Tapered Roller Bearings

- a. The principle of the tapered roller bearing (fig.

4) is simple. It consists of constructing the rolling elements, as well as the raceways, on the principle of the cone, so that lines drawn coincident with the working surfaces of the rollers and races will all meet at a common point on the axis of the bearing. Thus, true rolling motion is obtained and the bearing will handle both radial and thrust loads in any combination. The angle of the cone through the axis of the rollers varies, being larger for applications where extra heavy thrust loads are to be carried. As each roller revolves about the cone, wide area contact is made between the large end of the roller and the cone rib. This contact compels each roller to maintain accurate alignment. The rollers have a length of about twice their mean diameter.

b. In order to meet mounting conditions and load variations, tapered roller bearings are manufactured in a variety of designs.

7. Self-Alining Roller Bearings

a. Self-Alining Roller Bearings (figs. 3 and 4). These bearings are designed to operate under conditions of misalignment. One raceway, either the inner or outer, is spherical in form

and conforms to the shape of the rollers. Bearings employing rollers of barrel shape have the outer raceway spherical, while those using con cave (hourglass-shaped) rollers have the inner raceway spherical. In both styles, the center of the sphere lies in the shaft axis. Flanges on either the outer or inner race are used to guide the rollers.

b. Self-Alining Angular Contact Roller Bearings (fig. 3). Self-alining angular contact roller bearings are designed to carry both radial and thrust loads. The operating surface of the outer race has a spherical contour and the rollers and races make angular contact. The self-alining angular contact bearing, ordinarily, has a separable outer race with the rolling element and the inner race permanently assembled as a unit.

Some applications, such as steering gears, do not require an inner race as the rollers operate directly on the shaft which is suitable contact to conform to the roller contour.

8. Needle Bearings

a. General. Needle bearings employ a full row of

rollers of exceedingly small diameter, the roller diameter being about one-eighth the length. They are used chiefly for slow speed or oscillating applications. In many cases, they run directly upon a hardened and ground shaft, thereby dispensing with the inner race. Needle bearings in which there is no cage or separator retaining the individual rollers are in general use. The elimination of the cage or separator increases the effective bearing contact area and the load carrying capacity. Roller alignment is maintained through the use of controlled circumferential clearance or clearance between rollers. The five basic types of needle bearings are covered in b through f below.

b. Drawn Cup-Type Bearings (figs. 5 and 6). The drawn cup bearing assemblies consists of a drawn cup outer race and self-contained rollers with optional separable inner races. The bearings come in three basic roller sizes:

regular roller, large roller, and extra large roller. Figure 5 shows the close tolerances pertaining to the precision and extra precision series of drawn cup-type bearings.

AGO 2737A

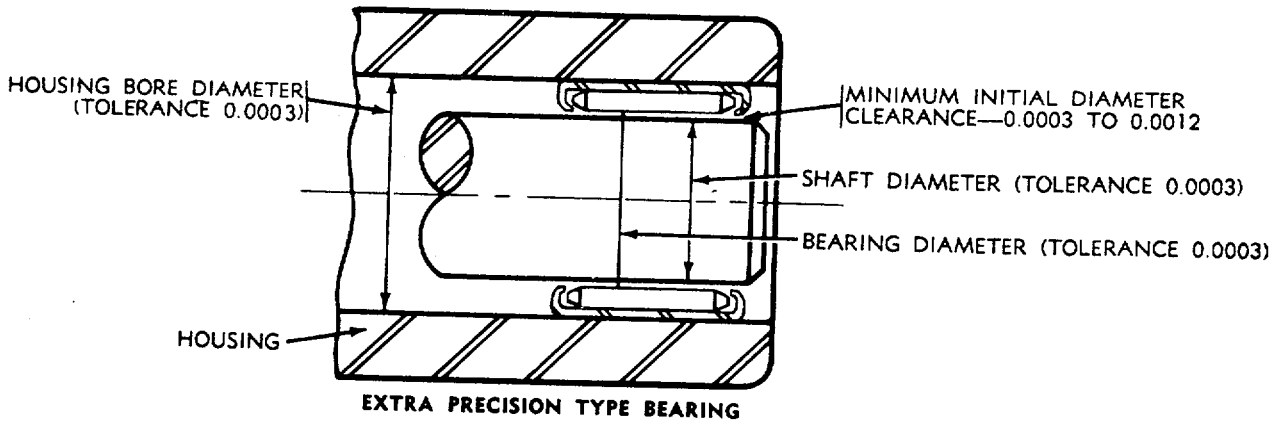
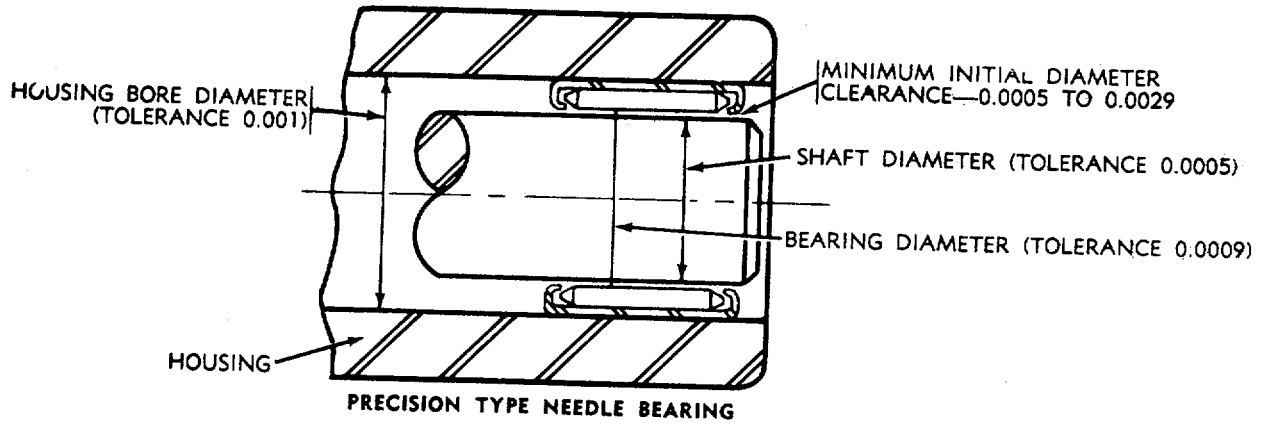
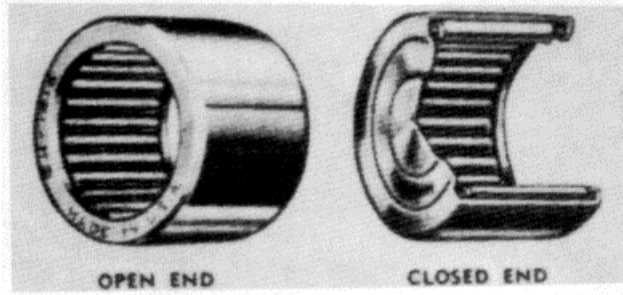

NOTES: 1—TOLERANCES AND RESULTING CLEARANCES SHOWN ARE FOR MEDIUM SIZE BEARINGS IN ROTATING APPLICATIONS
 2—ALL DIMENSIONS SHOWN ARE IN INCHES

RA PD 252753A

Figure 5. Drawn cup needle bearing assembly.

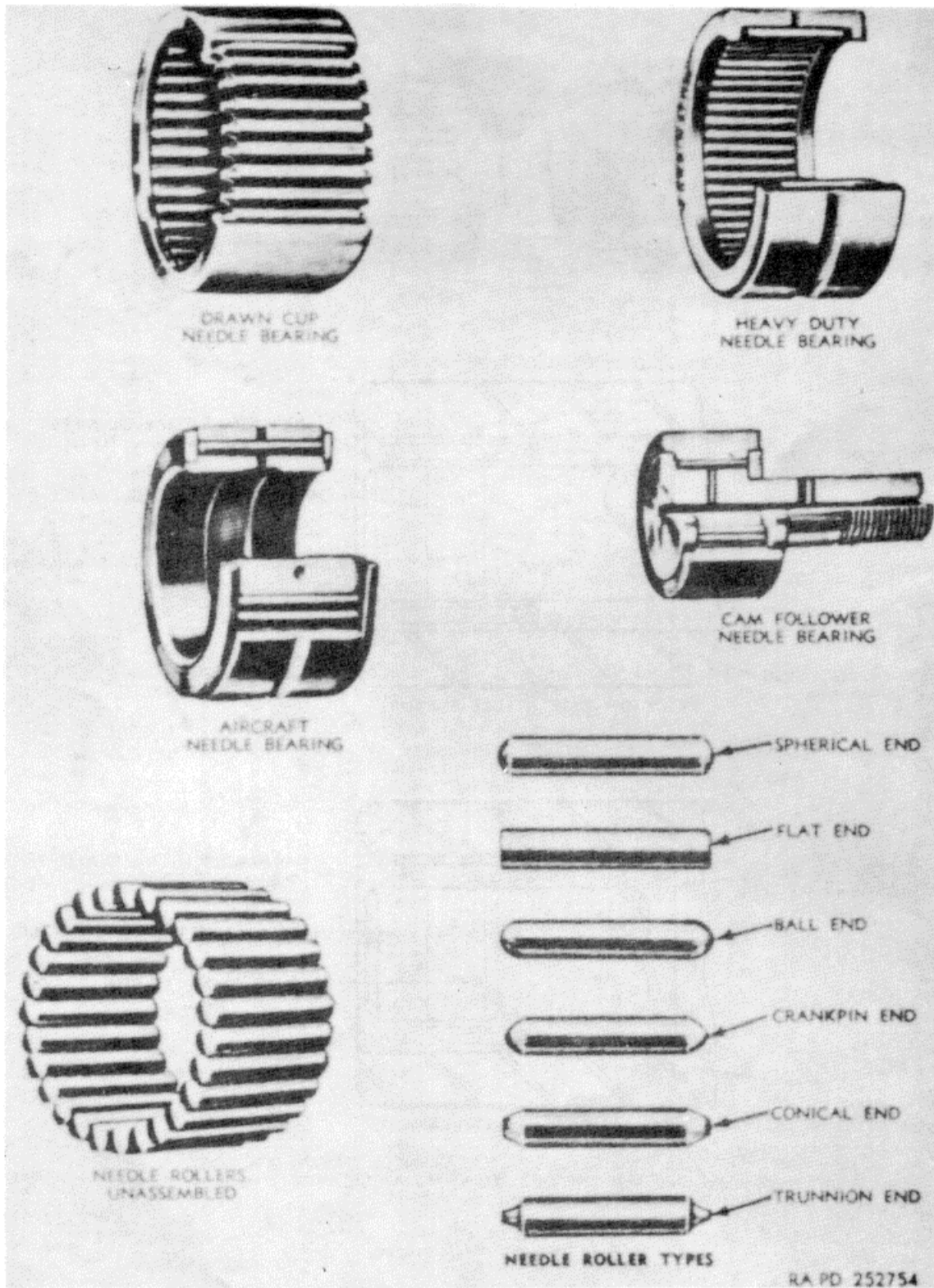

Figure 6. Types of needle bearings.

c. *Heavy Duty-Type Bearings* (fig. 6). The heavy duty bearing assemblies consist of the heavy duty outer race, self-contained rollers, and the optional separable inner race.

d. *Aircraft-Type Bearings* (fig. 6). Aircraft-type bearings of unit or nonseparable-type construction are used in applications involving high static or oscillating motion loads.

e. *Cam Follower-Type Bearings* (fig. 6). The cam or track roller needle bearing is a nonseparable unit consisting of outer race, rollers, stud, and a washer securely fastened to the stud. Cross-drilled holes in the

raceway and shank, as well as an axially drilled hole through the stud, are provided for lubrication. The axially drilled holes allow the use of a standard drive-type lubrication fitting in either end.

f. *Needle Roller Unassembled Type* (fig. 6). Needle rollers are available in various types, such as spherical end, flat end, ball end, crankpin end, conical end, and trunnion end as shown in figure 6. The needle rollers unassembled are commonly used in automotive transmissions, universal joints, automotive clutch fingers, steering gears, diesel engine cam followers, and camshafts.

AGO 2737A

Section III

BEARING REMOVAL

9. General

a. Press-fitted bearings should not ordinarily be disturbed. When it is necessary to remove the bearings, study the bearing installation and determine the best way to effect bearing removal. Removal of bearings must be accomplished with extreme care so that bearings, shafts, or housings will not be damaged.

b. When a piece of equipment is disassembled the bearings stay with the member to which they are tightly fitted. To remove a bearing press or pull only on the race which is tight (press-fitted). Bearings are removed from shafts by force applied to the inner race. Bearings are removed from housings where "tap fits" are used by pressure applied to the outer race. Press or pull straight and square (fig. 9) to keep the race from cocking. If the bearing is removed in a cocked position, it may score the shaft or housing, or the bearing itself may be damaged.

Caution: Never press or pull against a bearing shield or separator.

c. In cases where it is impossible to get a grip on the correct race and it is necessary to press or pull on the outer race, pull just enough to clear the tight race so that it is possible to grip it. Continue bearing removal by applying pressure on the tight race.

d. In bearings with separable parts, inner race, outer race, and ball or roller assembly, both races may be a tight fit. This may require the use of some improvised form of mechanical advantage for removal.

e. When hammers are used, as with a drift or tubing, they must be of steel. Soft hammers are liable to chip and the chips may fall into the bearing. However, for hammering directly on the shaft or other machine part a soft hammer, such as brass, must be used to avoid marking the shaft. Never pound directly on a bearing (fig. 16).

f. The best tool for removing a bearing is an arbor press (par. 10). Most field bearing removal work, however, is performed with some form of bearing puller (par. 11). Refer to 14 pertinent instructions in technical manuals on the materiel for the proper tool to employ.

10. Bearing Removal by Arbor Press

a. In removing bearings, it will be found that the majority of bearings have been assembled with a tight press fit holding the rotating race, and with a relatively free fit holding the stationary race. Removing the race with the free fit can be accomplished quite easily, but the race with the tight press fit will require considerable force which must be applied in such away that the bearings and machine parts are not damaged.

b. The arbor press (figs. 7 and 8) is one method of applying the force necessary to remove bearings or races from shafts and housings. It is rapid, smooth and positive, making it an especially useful tool where bearing removal work is performed. In addition, the arbor press supplies a greater force than is available from most other bearing removal equipment, making it possible to remove some bearings which might not be removable by bearing pullers or by hammering.

c. Regardless of the method used to remove bearings or races, it is important that the driving force be applied to the press fitted race. For example, if a nonseparable bearing is to be removed from a shaft, the force should be applied to the inner race and not to the outer race, rollers, or separator (fig. 9). With the arbor press, this is accomplished with the aid of fabricated accessories as outlined in (1) through (3) below.

- (1) A pair of flat steel bars that are the same size and squared up on all sides to assure even contact are placed beneath the inner bearing race adjacent to the shaft as shown in figure 10.
- (2) A U-shaped flat steel bar as shown in figure 10 is preferable when this operation has to be repeated often.
- (3) A third type of accessory is the steel split ring, a circular ring bored slightly larger than the shaft diameter and cut into two semicircular segments (fig. 10).

d. The arbor press can only be used to remove races or bearings from housings which are so designed that some portion of the outer race can be exposed. In cases where the entire face of the outer race is exposed, use a pipe or tubing capped by a steel block as shown in figure 11. In other cases, such as the automobile front wheel hub, the shoulders against which the outer races rest are slotted to allow a flat steel bar to contact the outer race in two diagonally opposite places as shown in figure 11.

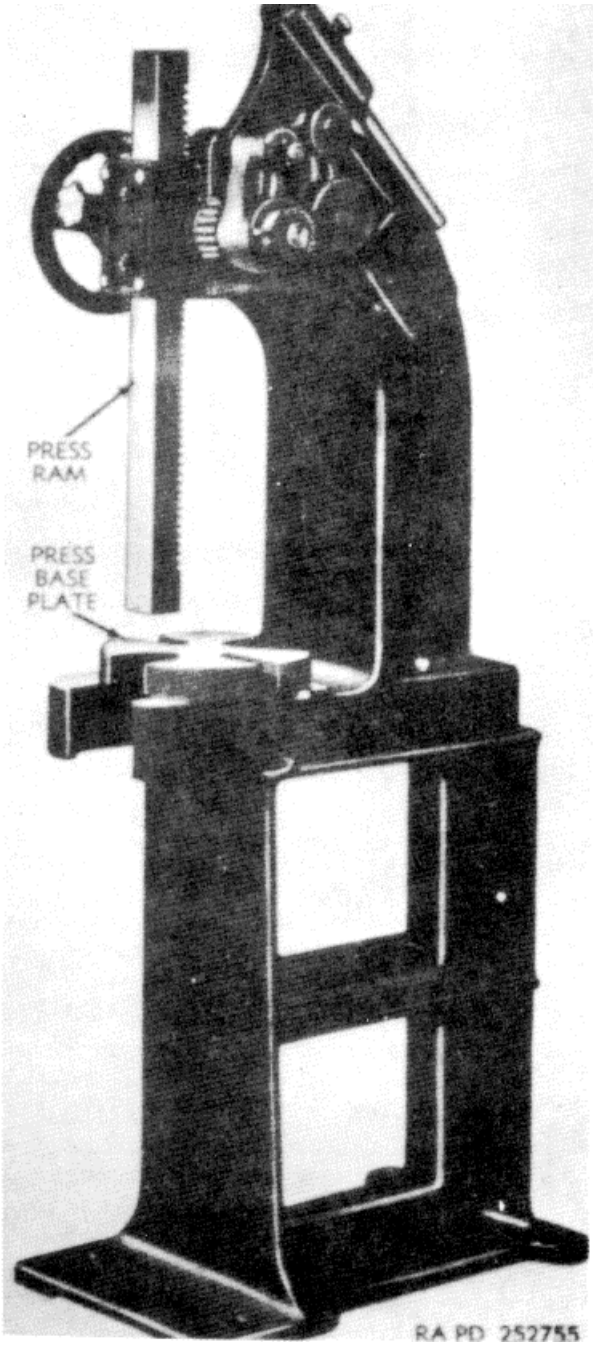

Figure 7. Arbor press with floor stand.

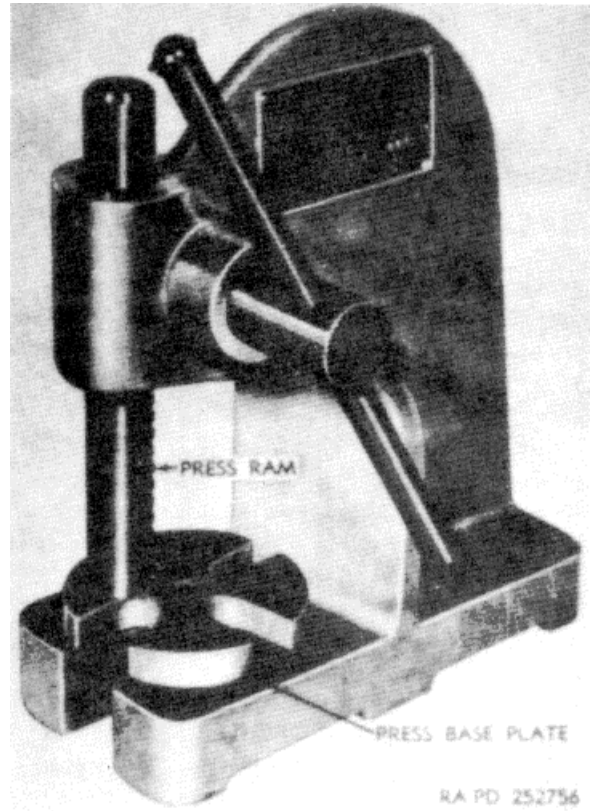

Figure 8. Arbor press-bench type.

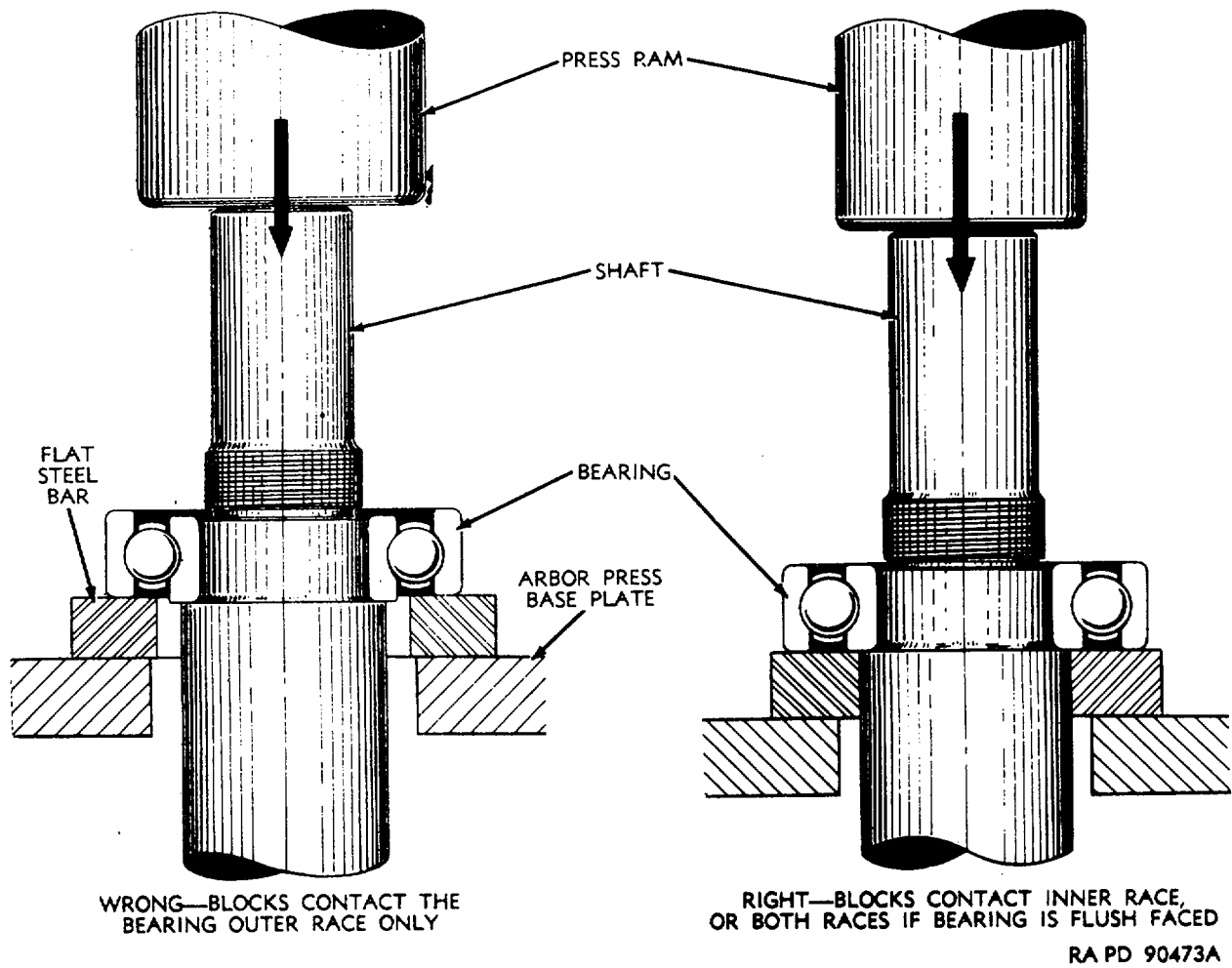

Figure 9. Correct method of removing a bearing.

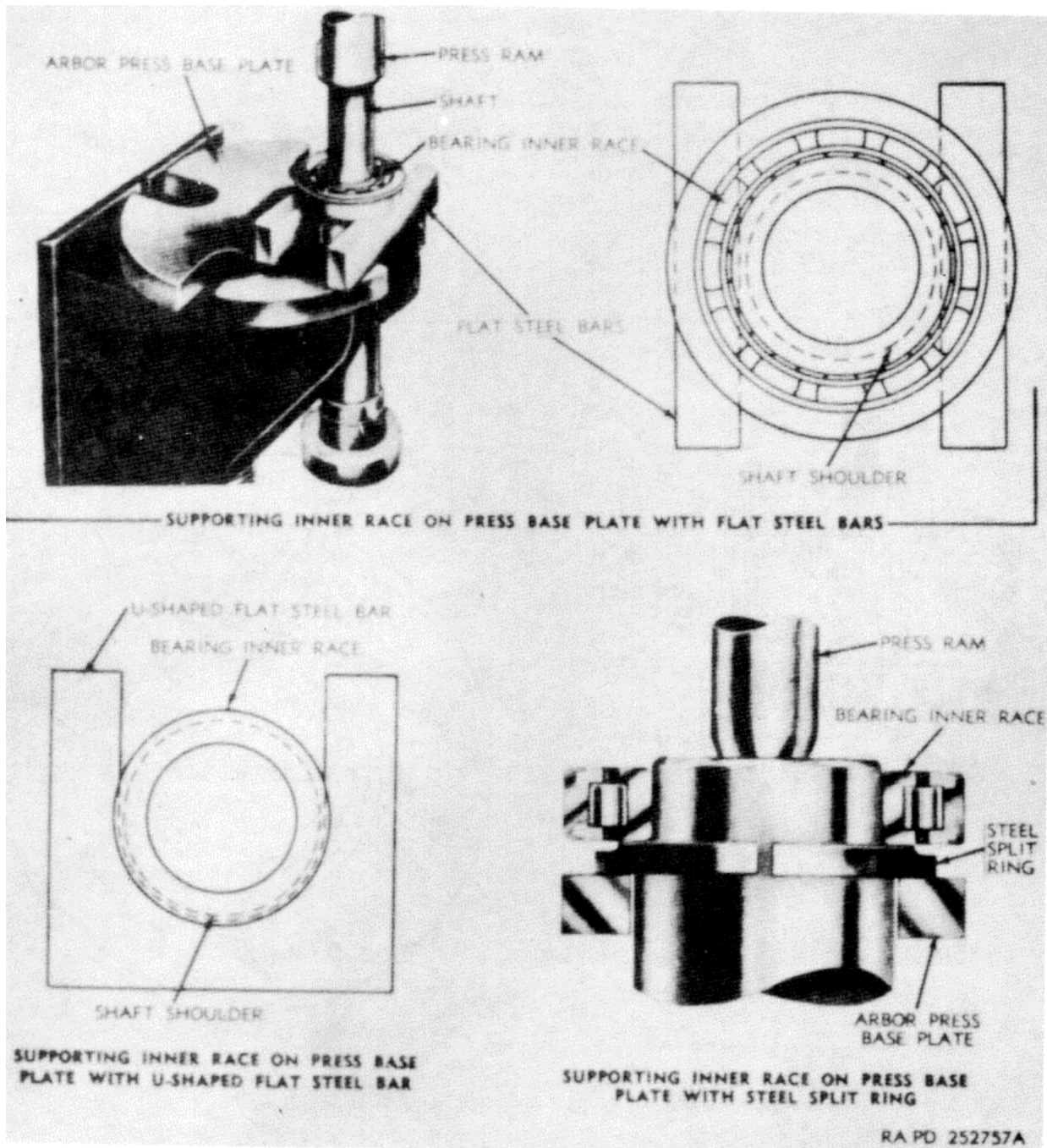
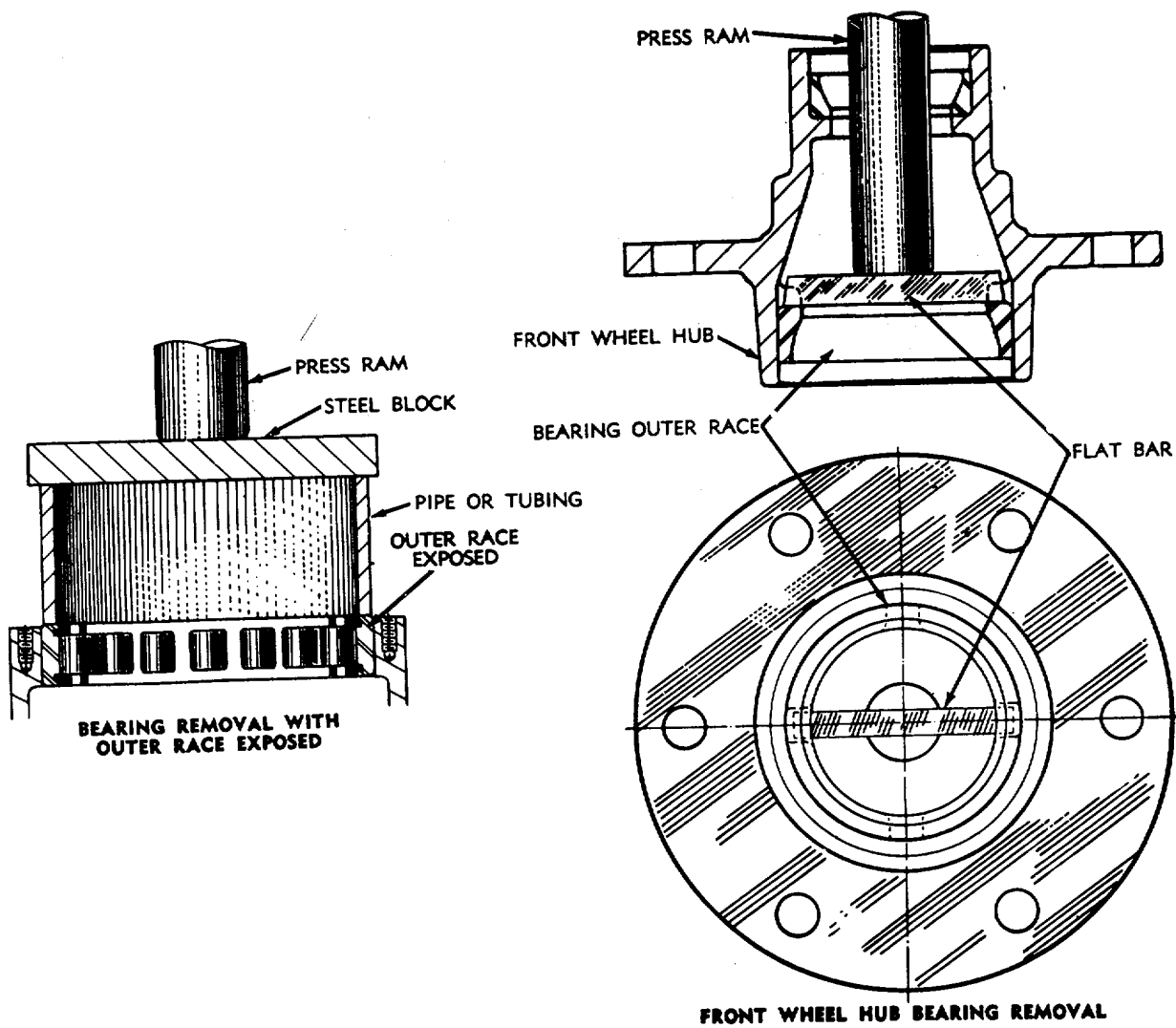

Figure 10. Method of supporting inner race on press base plate with fabricated steel accessories.

AGO 2737A

153-862 0 - 94 - 2



RA PD 252758A

Figure 11. Method of bearing removal with outer race exposed.

11. Bearing Removal by Bearing Pullers

a. Bearing pullers are used for removing bearings when no arbor press (par. 10) is available, or when the shaft is too large or is obstructed and cannot go into a press. Various types of bearing pullers are shown in figures 12, 13, and 14. They include accessories and methods by which they may be used to remove bearings and races from shafts and housings.

b. Apply bearing pullers so that the force is applied to the pressfitted race and no force is carried through the rolling elements or the snaprings (fig. 12).

c. In some applications, a gear, pulley, or cover plate may be used instead of the split collar puller plate (fig. 12). When bearing pullers having adjustable legs are used, the legs must be of equal length and symmetrically placed. (Refer to (1) and (2) below for methods of removing inner and outer races.)

Note. Attach pullers to bearings accurately so they will push or pull straight and square making certain that shaft threads, keyways, or

shoulders are not damaged in the process of bearing removal.

(1) *Inner race removal.* The removal of inner races or bearings from shafts is accomplished by the push-puller in conjunction with the split collar puller plate as shown in figure 13. The pushpuller is adjustable in breadth and length, and can be regulated by using legs of various sizes.

(2) *Outer race removal.* The removal of outer races from housings is accomplished by the push-puller in conjunction with the bearing cup pulling attachment as shown in figure 14. The bearing cup puller attachment is attached to the push-puller by means of a reducing adapter. This method of outer race removal is particularly useful in blind holes which might otherwise require cutting the race with a torch or necessitate damage to the housing.

AGO 2737A

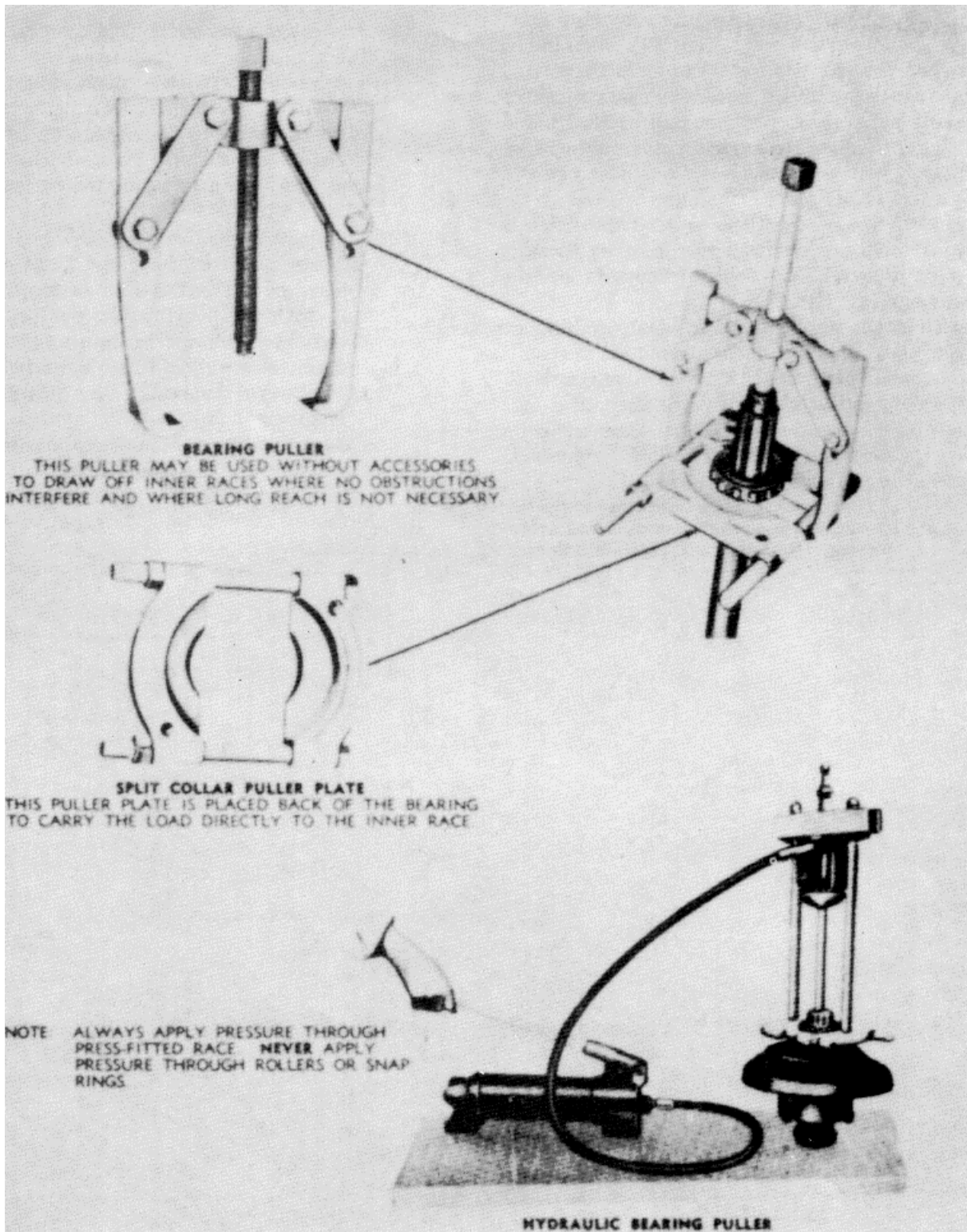

Figure 12. Various types of bearing pullers and accessories.

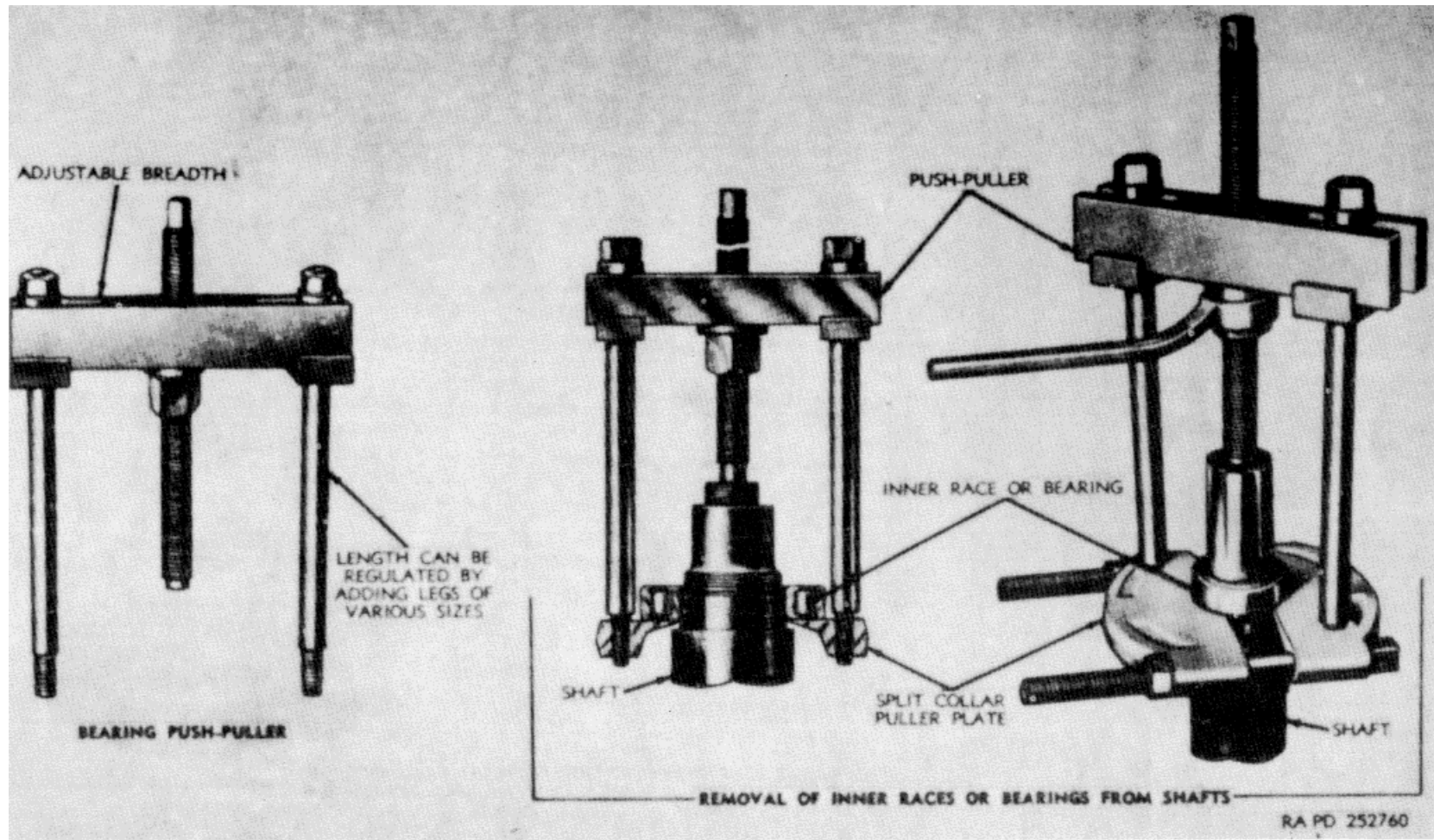

Figure 13. Inner race removal.

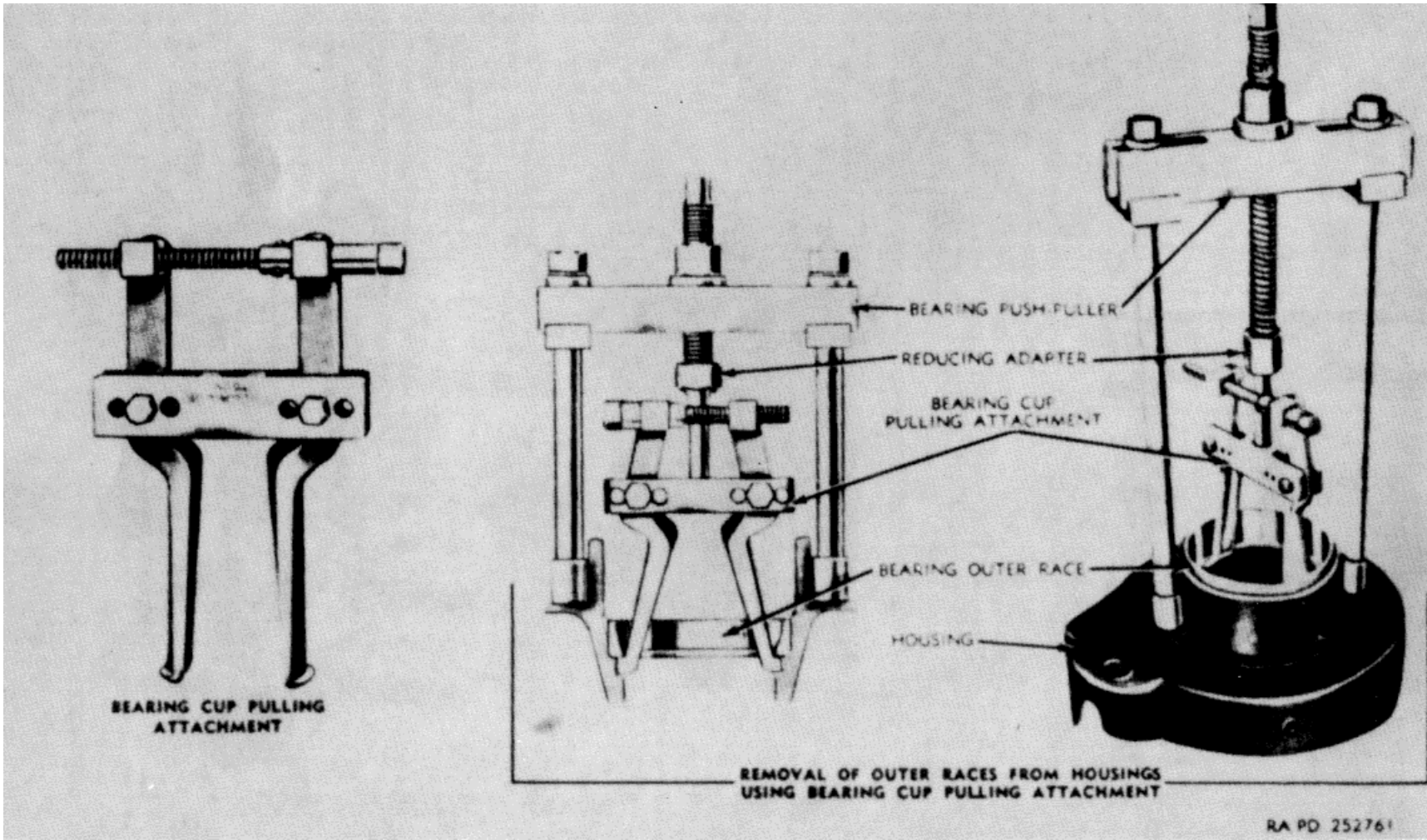

Figure 14. Outer race removal.

AGO 2737A

12. Bearing Removal by Driving

a. General. The removal of bearings or races by driving with a hammer or mallet is the most common method used, but it is the least desirable. It should be resorted to only when no other means are available. The reason for this is that driving can easily damage the bearing or cause injury to the operator. However, there are times when no other method can be used. In order to prevent damage to the bearing or injury to the operator when driving methods are used, the operator must observe the precautions listed in (1) through (9) below.

- (1) Wherever possible, mount the shaft or housing in a vise. Use wood blocks, leather or soft metal guards to protect the shaft or housing from damage by the vise jaws (fig. 15).
- (2) Do not use wood or very soft metals to drive the bearings or races. Do not use hardened drifts, cold chisels, or center punches. Be sure the driving tool is of unhardened mild steel. The hardened bar, chisel, or center punch may damage the bearing, and the soft metals and wood will chip easily. These chips may get into the bearing to cause damage or may get behind the bearing face and prevent proper bearing seating.
- (3) Do not hammer directly on bearing races, cages, or roller assemblies (fig. 16).
- (4) Always direct the driving force against the face of the pressfitted race to avoid damage to the separators, rollers, or bearing operating surfaces.
- (5) If none of the accessories illustrated in figure 17, 18, or 19 are available, use an unhardened mild steel drift and steel hammer to tap off the races (fig. 15).
- (6) In driving, use smart, quick taps, rather than heavy blows. This will prevent the race from cocking and damaging the shaft.
- (7) Tap alternately on opposite sides of the race to make certain that the race will move uniformly-off the shaft.
- (8) Work in clean surroundings with clean tools and clean hands (fig. 24).

- (9) Wear protective clothing, goggles or glasses, and gloves, as required, in order to prevent personal injury.

b. Driving Bearing With Pipe or Tubing (fig. 17). Sections of pipes or tubes are the simplest accessories that can be used to aid in driving a race or bearing off a shaft or out of a housing.

The size of the pipe or tube should be such that only the race to which the driving force is being directed is contacted. The inside diameter of the tube should be slightly larger than the shaft, so that the shaft acts only as a guide and prevents the tube from damaging the snaprings or separator. The tube end in contact with the bearing should be square and clean. Use a steel block as a cap to distribute the force of the hammer blows over the end of the tube. The block also should have square and true faces and should be clean.

c. Driving Bearing With Pipe or Tubing With Long Shafts (fig. 18). If the shaft is too long to use a pipe and steel block conveniently, weld lugs on two opposite points of the outside diameter of the pipe or tube. Drive against these lugs on opposite sides alternately in order to move the race uniformly. Where obstructions prevent a tube from being slipped over the shaft, split the tube and assemble the two halves around the shaft and secure them together by means of wire, steel bands, or heavy cord.

d. Driving Bearing With Drive Blocks (fig. 19). Drive blocks are preferable to pipes or tubing, but their use is limited to certain applications or conditions. They cannot be used with very large bearings or where the back face of the inner race is obstructed.

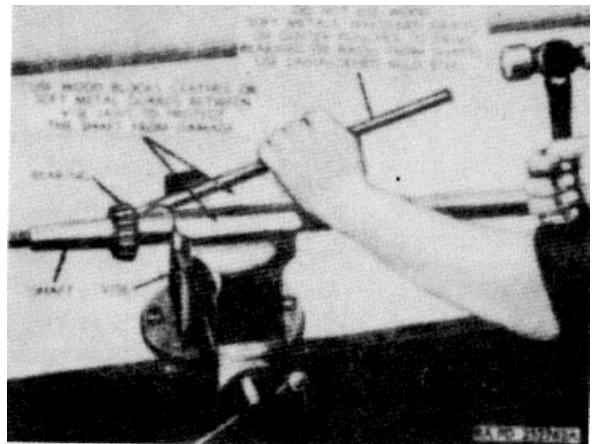

Figure 15. Method of driving bearing with metal bars.

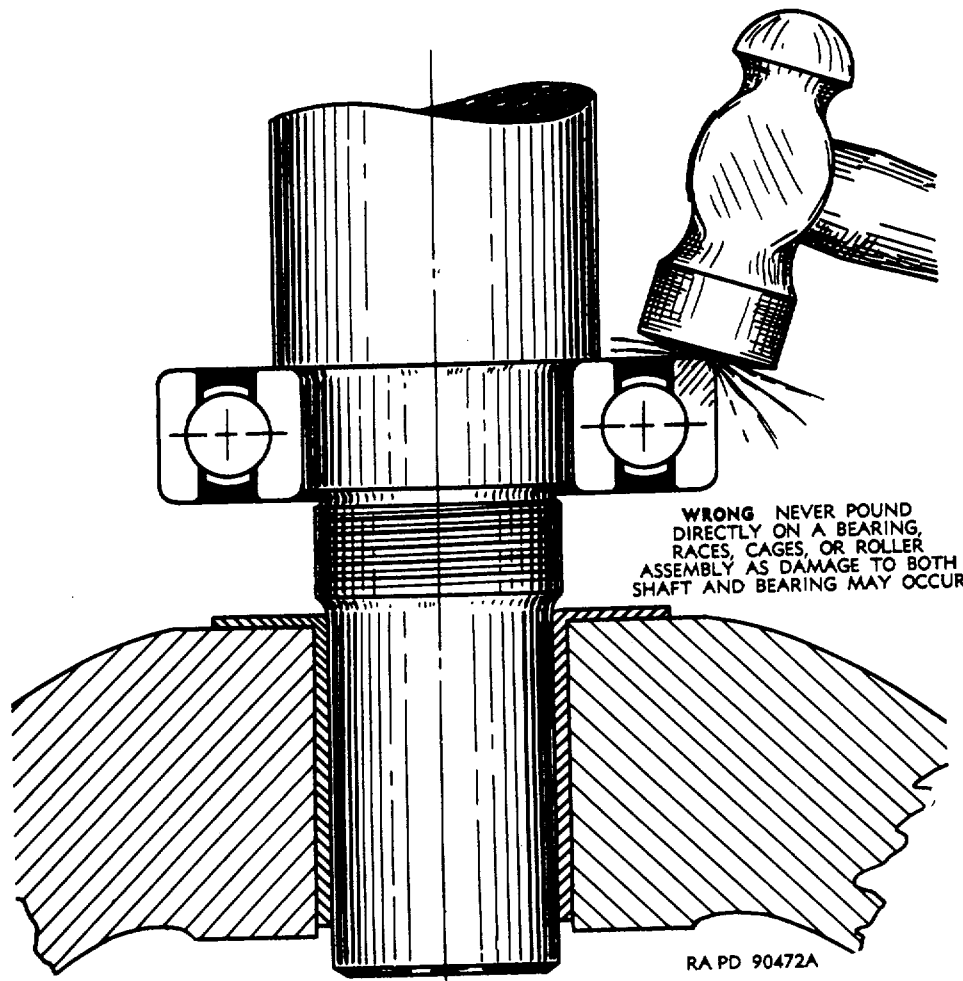
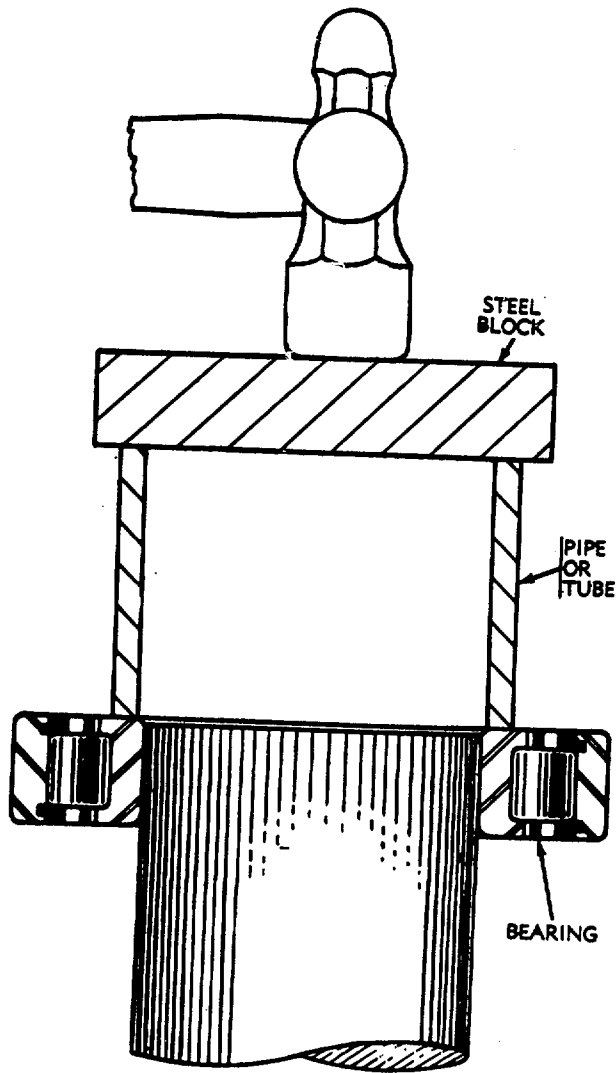

Figure 16. Wrong method of driving bearing.



NOTE:
 PIPE OR TUBING MAY BE USED IN CONJUNCTION WITH AN ARBOR PRESS AS WELL AS WITH A HAMMER. THE PRESSURE MUST BE DISTRIBUTED OVER THE END OF THE TUBE BY MEANS OF A STEEL BLOCK OR CAP.

RA PD 252783

Figure 17. Driving bearing with pipe or tubing.

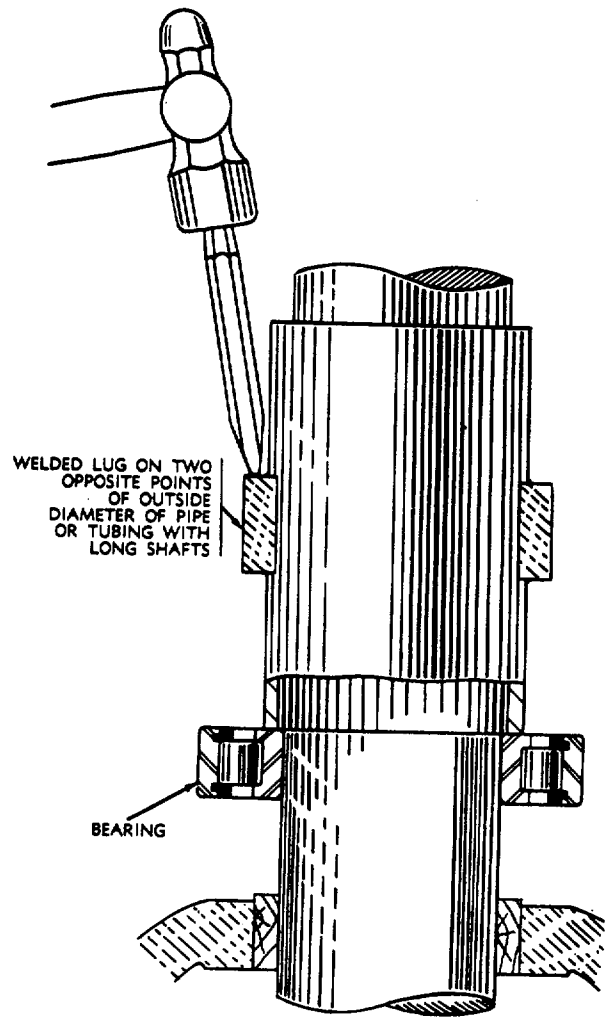

Figure 18. Driving bearing with pipe or tubing with long shafts.

AGO 2737A

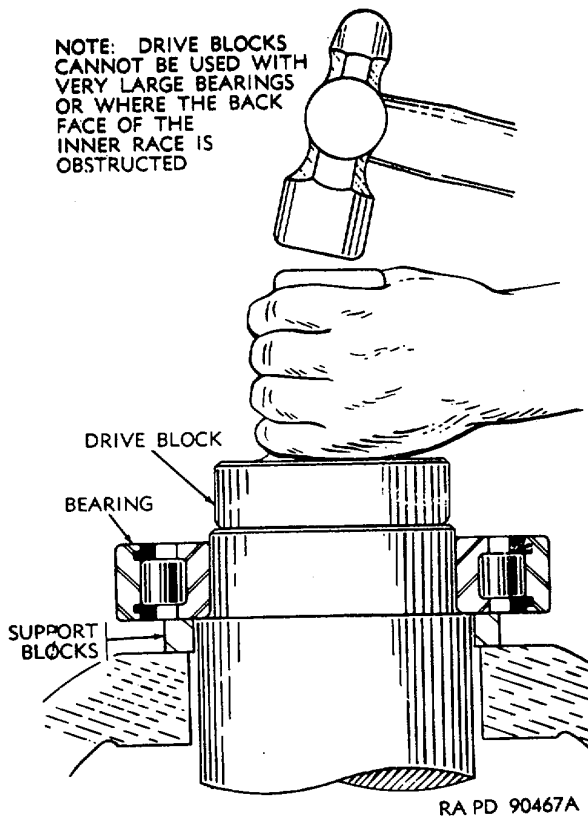

Figure 19. Driving bearing with drive blocks.

13. Bearing Removal by Heating, Grinding, Burning, or Splitting

a. Bearing Removal by Heating.

- (1) When the force necessary to remove the bearing parts is greater than the capacity of the available equipment, heat may be used to assist in removing the races from their shafts.

Note. Heating is not generally recommended because of the danger of overheating, temper drawing, and the development of soft spots leading to failure when the bearing is later in use.

- (2) Where the race to be removed has already failed or is not intended for further use, precautions must still be taken to protect the shaft from overheating.

- (3) The approved method of applying heat is by pouring hot oil over the race. It may be necessary, however, to use a direct flame from a blowtorch. The race must not be heated above 250° F., because above this point there is danger of softening. Wet cloths wrapped around the shaft may prove effective in carrying away excessive heat.

b. Bearing Removal by Grinding, Burning, and Splitting (fig. 20).

- (1) When no other method of race removal can be used, the race must be completely destroyed. Removal of race by destruction must be accomplished in such a manner that the shaft will not be damaged. This usually involves grinding of acetylene flame burning the race partially through. Either of these procedures reduce the pressure between the race and shaft and permit removal. If not, it may be necessary to cut through the rest of the race with a hammer and cold chisel.
- (2) Do not direct the chisel toward the shaft, but directly against the side of the groove which has been cut in the race.
- (3) When small races are mounted on shafts, a sharp blow may be sufficient to crack the race.

Warning: Take adequate precautions to prevent personal injury from flying parts.

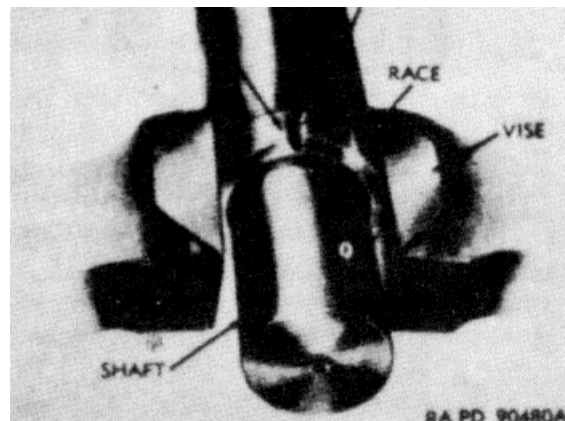

Figure 20. Bearing removal-by grinding, burning, and splitting.

14. Needle Bearing Removal

a. Removal of Needle Bearings From Housing With No Shoulders.

- (1) Needle bearings with a pressfit and mounted in straight housings without locating shoulders may be removed without damaging either the housing or the bearings by inserting the bearing housing in an arbor press and using a pusher-type bearing removal tool or improvised special pressing tool.

Note. Before removing the bearing, examine the housing and remove any burrs.

- (2) The bearing is then removed by pushing against the stamped end of the bearing using a steady even push.
- (3) If two bearings are mounted in the same housing, the same procedure prescribed in (2) above is used for removal. The two bearings are pushed together, then both are pushed out as a unit.
- (4) With closed end bearings, a similar procedure may be used. The pusher is the same except that the pilot is omitted. The pusher contacts the bearing only at the outside of the closed end. The center of the pusher is entirely free.
- (5) When necessary, remove closed end bearings by pushing on the open end and on the inside of the closed end at the same time.

b. Removal of Needle Bearings From Shouldered Housings (fig. 21).

- (1) Needle bearings may be removed from shouldered housings, without damaging the housing, with an improvised bearing removal tool. This tool is slotted in two places at right angles to form four prongs. Then it is hardened and spring-tempered. The prongs, pressed together for insertion, are expanded by inserting the expansion bar.

- (2) When it is possible to place the bearing tool pusher behind a bearing, as shown in figure 21, it may be pushed out.

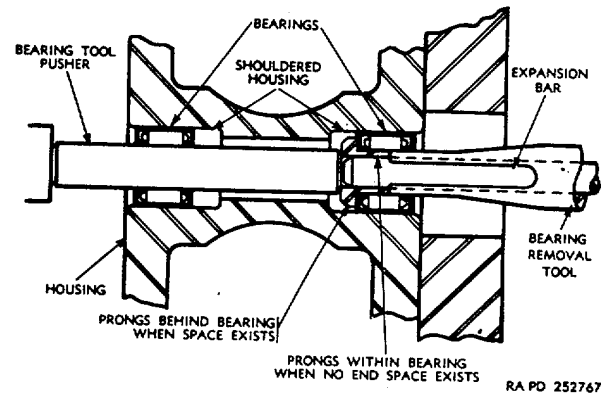

Figure 21. Improved prong-type tool for removal of two needle bearings mounted in shouldered housings.

c. Removal of Needle Bearings From Front of Shouldered Housings (fig. 22).

- (1) When removal has to be done from the front, it is possible to thread the body of the removal tool and to use a large nut with a thrust washer between it and the housing. This puller-type tool works in the same manner as a common gear puller.
- (2) In removing a bearing which has been pushed tight against a shoulder, the same type of improvised tool as shown in figures 21 and 22 may be used, but the needle rollers must first be removed.
- (3) The easiest way to remove needle rollers is to grind a slight notch on the outside lip of the bearing with a small hand grinder. The bearing outer race (sometimes called shell) may then be removed by expanding the tool inside the outer race and pushing or pulling with a steady, even press against the front lip.

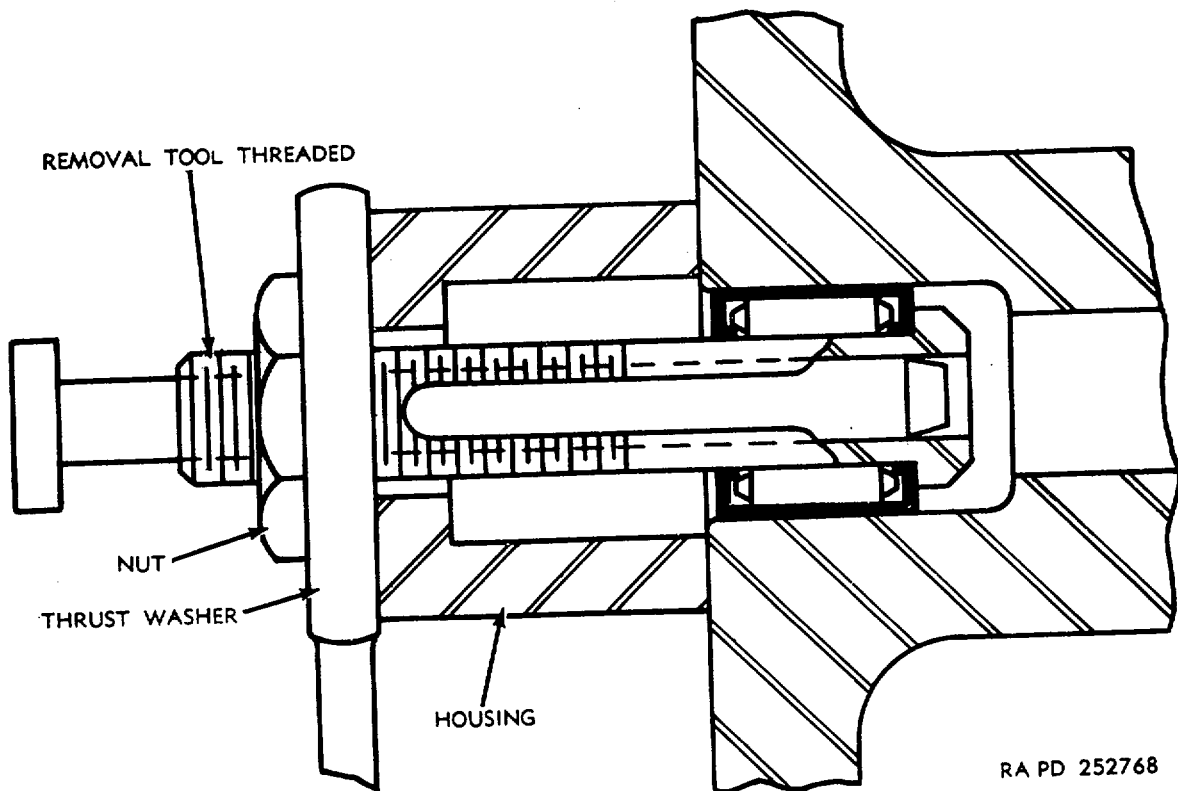
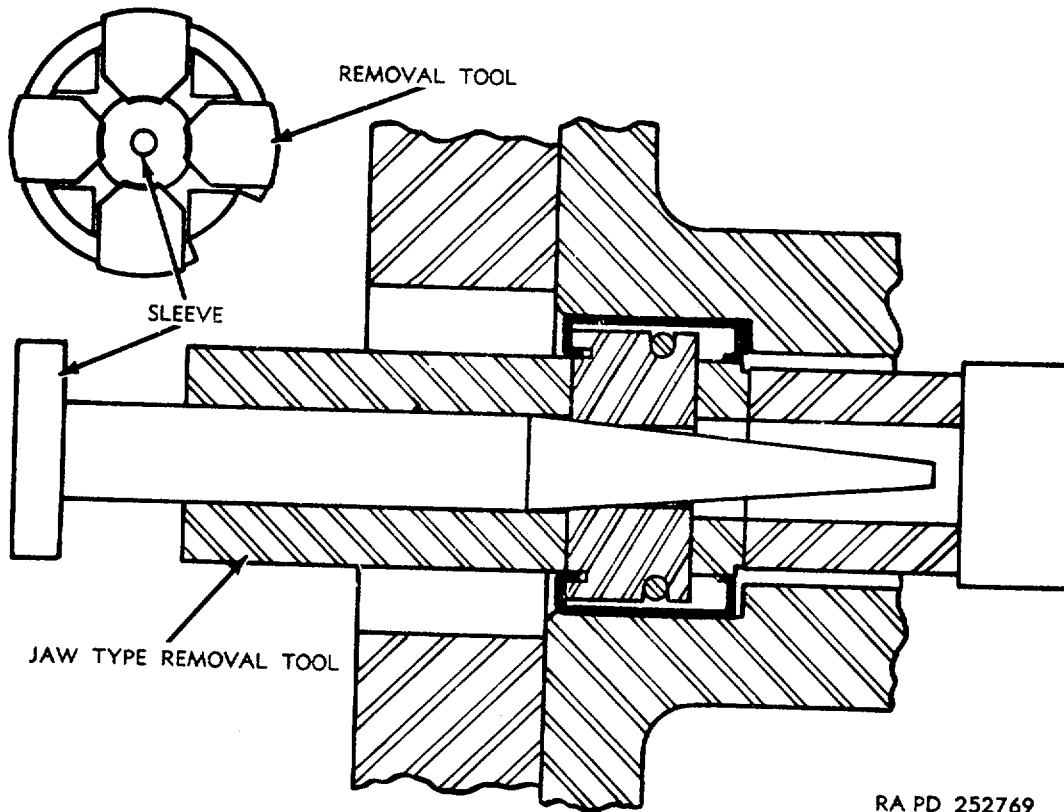

Figure 22. Improvised puller-type tool for removal of needle bearing from front of shouldered housing.

d. Removal of Larger-Type Needle Bearings (fig. 23).

(1) On larger-type needle bearings, where room is available, a separate jaw type of tool is better than the spring-tempered prong type. This is a hollow tube with four openings or windows near one end to receive the four jaws.

(2) The four jaws slide in and out of the openings. When they are pushed fully in, the tool may be inserted into the outer race from which the rollers have been removed. The jaws are then pushed out by using a hollow sleeve as shown in figure 23.



RA PD 252769

Figure 23. Improvised jaw-type tools for removal of larger-type needle bearings.

e. Removal of Needle Bearings Front Dead-End Housing.

- (1) Some types of housings from which needle bearings must be removed are the dead-end type. This type is common in gear pumps and electric drills.

- (2) The puller-type tool (fig. 22) and the separate jaw-type (fig. 23) may be used to remove bearings from dead-end housings. In most cases, however, it will be necessary first to remove the needle rollers from the bearings.

AGO 2737A

Section IV

CLEANING, DRYING, AND DEMAGNETIZING BEARINGS

15. General

a. Reconditioning of antifriction bearings is not authorized; therefore, visually inspect dirty bearings and immediately discard those bearings found unserviceable. As cleaning procedures progress, continue to inspect and discard unserviceable bearings as they are found (pars. 21 and 22).

b. Dirty antifriction bearings must be thoroughly cleaned, dried, and demagnetized prior to lubrication or installation. Dirt is the most common cause of bearing failure and the principle cause of wear. When dirt gets into a bearing, it mixes with the grease or oil and forms a "lapping or grinding compound" that quickly wears the balls or rollers. The word "dirt" is used in a broad sense and includes all foreign matter which may enter and cause damage to the bearings.

c. Deleterious substances most likely to enter bearings may be divided into three groups as outlined in (1) through (3) below.

- (1) Abrasive materials that are of sufficient hardness to cut or scratch, such as emery dust, particles from grinding wheels, or sand and grit contained in contaminated lubricants.

- (2) Obstructive materials such as metal particles, small chips, or improper lubricants that are not hard enough to cut, but are of sufficient strength to interfere seriously with the rotation of the bearings.
- (3) Clogging substances which may gradually accumulate in the bearing and will prevent proper lubrication, reduce the clearance between parts, and interfere with smooth bearing operation.

d. Cleanliness in bearing maintenance cannot be overstressed. Rooms in which work is being performed on bearings must be well illuminated and as free as possible from dust, dirt, moisture, corrosive fumes, and other agents detrimental to bearings.

e. All machines, equipment, materials, and supplies used in processing bearings must be kept clean and free from contamination which may affect the bearing adversely.

f. All work must be accomplished with clean tools and in clean surroundings (fig. 24). Refer to table I for general information pertaining to bearing cleaning, handling, drying, etc.



Figure 24. Bearing processing area.

Table I. Things to Remember

Do	Do not
<p>Do remove all outside dirt or contaminants from housing before exposing bearing.</p> <p>Do treat a used bearing as carefully as a new one.</p> <p>Do work with clean tools and in clean surrounds.</p> <p>Do use clean cotton or synthetic rubber gloves, or a clean, lint-free cloth when handling bearings.</p> <p>Do use clean solvents and lubricants.</p> <p>Do lay bearings out on clean grease-proofed barrier material.</p> <p>Do protect disassembled bearings from possible corrosion at all times.</p> <p>Do use drying procedures as prescribed in paragraph 19 for drying bearings.</p> <p>Do keep bearings wrapped in grease-proofed barrier material when bearings are not in use.</p> <p>Do clean and, if necessary, repaint the inside of the housing before replacing bearings.</p> <p>Do use separate containers for cleaning and final rinsing of bearings.</p> <p>Do install new bearings as removed from packages without cleaning.</p> <p>Do keep bearing lubricants clean when applying them and cover lubricant containers when not in use.</p> <p>Do align a bearing before and during installation of a shaft or bearing. Keep it straight and square while under a force. This also applies to removal.</p>	<p>Do not process bearings in dirty surroundings.</p> <p>Do not use dirty, brittle, or chipped tools.</p> <p>Do not use wooden mallets or work directly on wooden bench tops.</p> <p>Do not handle bearings with dirty or moist hands.</p> <p>Do not use gasolines containing tetraethyl lead or carbon tetrachloride because fumes from these may be injurious to health of personnel.</p> <p>Do not spin uncleaned bearings.</p> <p>Do not spin bearings with compressed air.</p> <p>Do not use cotton waste or dirty cloths to wipe bearings or housings.</p> <p>Do not expose bearings to moisture or dirt at any time.</p> <p>Do not scratch or nick bearing surfaces.</p> <p>Do not use the same container for cleaning and final rinsing of bearings.</p> <p>Do not remove grease or oil from new bearings.</p> <p>Do not use incorrect type or amount of lubricant.</p> <p>Do not cock a bearing during installation or removal while under a force. Press or pull it out straight and square</p>

16. Methods of Cleaning Open Bearings

a. *General.* Dirty bearings must be thoroughly cleaned by one of the methods listed in b through e below. It is essential that whichever cleaning method is used, no residues are left which may react unfavorably with the lubricant or may be unstable and decompose to form corrosive deposits. For this reason, a final thorough cleaning with dry-cleaning solvent or mineral spirits paint thinner is required.

b. *Initial Cleaning by Hand.*

- (1) When cleaning bearings by hand, the initial cleaning is generally accomplished by complete immersion in drycleaning solvent 6850-264-9037 (55gal. drum)* or mineral spirits paint thinner 8010 246 6115 (55gal. drum) * accompanied by such wiping, scrubbing, and agitation as may be necessary to accomplish through cleaning.

Caution: Do not spin dirty bearings, as dirt may cause serious scratching (fig. 25). Rotate them slowly while cleaning.

- (2) If the lubricant on the bearing is gummed or caked, it may be necessary to soak the bearing for a few hours or overnight suspended in a wire basket or from a piece of wire in one of the above cleaning agents. In stubborn cases, where the lubricant is badly gummed or caked, it may be necessary to soak the bearing in light engine oil (SAE 10) 9150-292-9691 (55-gal. drum) * heated to 180° F. After soaking, thoroughly flush the bearing by slushing slowly through the hot oil. In extreme cases, use hot 100 percent paraffin base oil or a mixture of 5 percent denatured alcohol and 95 percent kerosene, or a mixture of 5 percent denatured alcohol and 95 percent drycleaning solvent.

Caution: In such extreme cases, be sure that there is no open flame in the vicinity.

- (3) Following any of the extreme procedures in (2) above, wash the bearings in dry-cleaning solvent or

*It larger or smaller quantities than indicated are required, refer pertinent supply manuals for applicable stock numbers .



Figure 25. Never spin dirty bearings.

in dry-cleaning solvent or mineral spirits paint thinner. The bearings are then drained. This preliminary cleaning and draining is then followed by further cleaning and rinsing by complete immersion in a clean supply of dry-cleaning solvent or mineral spirits paint thinner, thus completing the initial cleaning

procedure. The initial cleaning is then followed by fingerprint removal as prescribed in f below.

Caution: During the subsequent and final cleaning, use extreme care to prevent the handling of bearings in any manner which may result in contamination of the surfaces with foreign matter, particularly fingerprints. Wear clean cotton or synthetic gloves, or use a clean cloth when handling or processing bearings. If this handling procedure is violated, the entire cleaning process must be repeated.

c. *Initial Oil Spray Cleaning.* An oil spray cleaner equipped with a filter in the air line may be used for cleaning bearings (fig. 26). After cleaning with the oil spray, rinse the bearings in a clean container using clean dry-cleaning solvent or mineral spirits paint thinner. The initial oil spray cleaning is then followed by fingerprint removal as prescribed in f below.

d. *Initial Cleaning by Power Flushing.* In cleaning bearings by power flushing, use warm dry-cleaning solvent. Rotate the bearings slowly and spray with dry-cleaning solvent, using an air-operated spray gun (fig. 27). The air pressure should be kept at 10 pounds

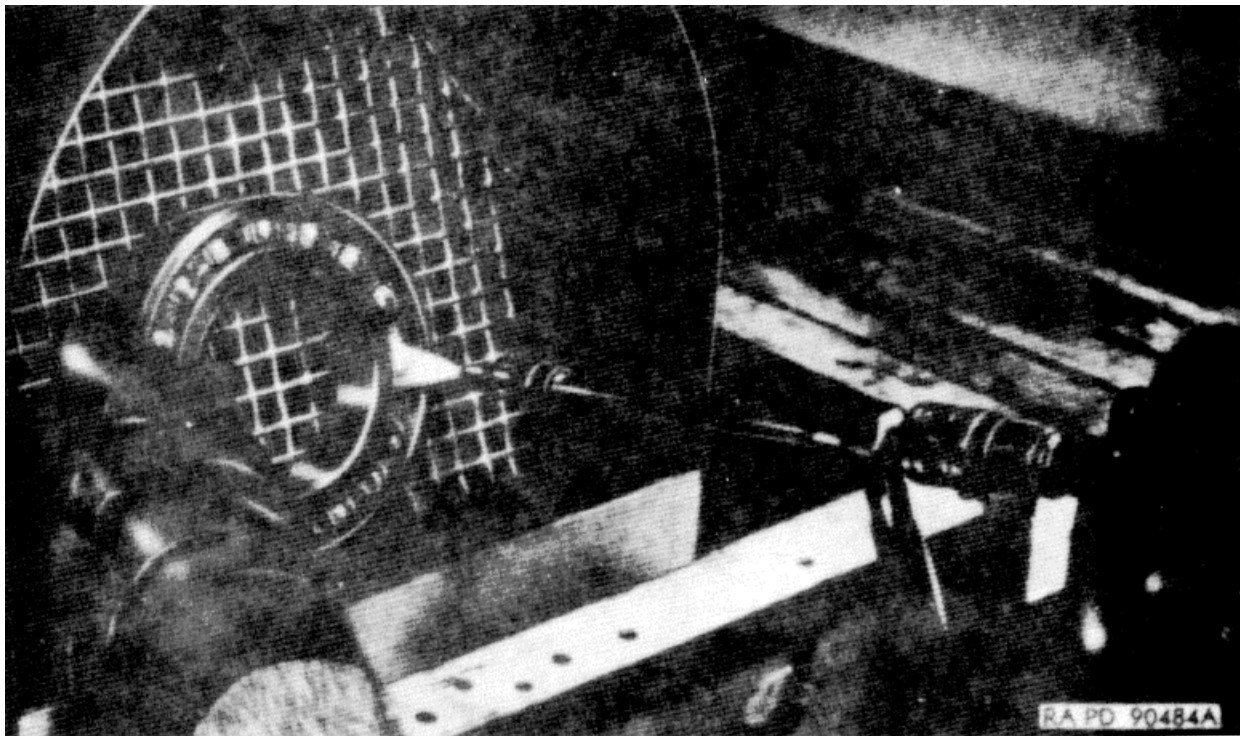

Figure 26. Oil spray cleaner.

AGO 2787A

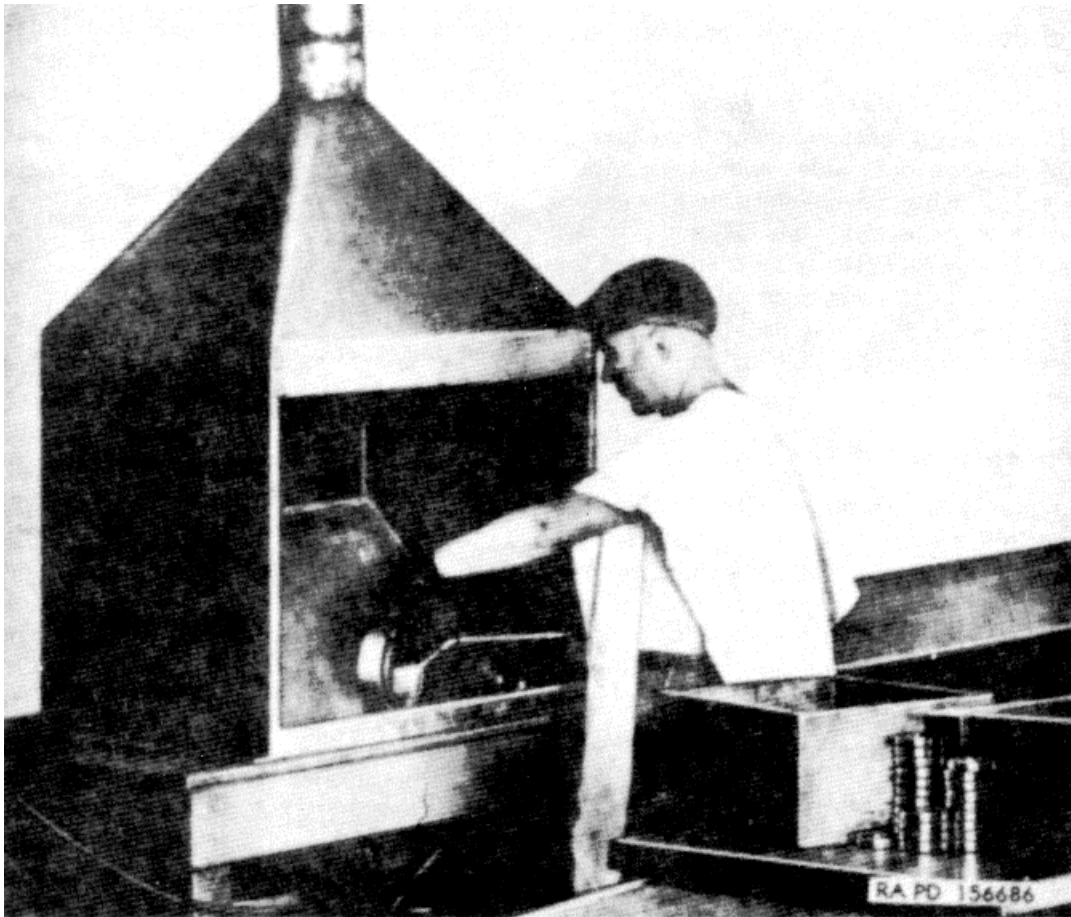

Figure 27. Power flushing bearing with spray gun.

pressure or lower if satisfactory results are to be obtained. The initial power flushing is then followed by fingerprint removal as prescribed in f below.

Warning: Keep dry-cleaning solvent and mineral spirits paint thinner away from open flame.

e. *Initial Cleaning by Vapor Degreasing.* This is a hot-vapor cleaning process involving the use of trichloroethylene or tetrachloroethylene. The bearings to be cleaned are placed in a wire basket and suspended in the vapor of the cleaning agent until no further condensation occurs on the bearing. The initial vapor degreasing is then followed by fingerprint removal as prescribed in f below.

Note. For complete information on the operation and maintenance of a vapor degreaser and the necessary fire and health hazards, refer to TB ORD 584.

f. *Fingerprint Removal.* Following any of the initial cleaning methods outlined in b through e above, removal or neutralization of perspiration or fingerprints, or similar residues is accomplished by immersing and agitating the

bearings for a minimum period of 2 minutes in fingerprint remover corrosion preventive 8030252-8301 (55-gal. drum)* or methanol 6810201-0908 (1-gal. can)*. The bearings are then given a final rinsing in clean, dry-cleaning solvent or mineral spirits paint thinner.

Caution: Methanol should not be used if other satisfactory cleaners are available. Methanol (wood alcohol) is a poison and a dangerous fire hazard.

17. Cleaning Bearings Having Seals or Shields

a. *Bearings With Shield or Seal on One Side* Bearings having a shield or seal on one side may be cleaned by any one of the initial cleaning methods outlined in paragraph 16.

b. *Bearings With Removable Seals.* Remove the seals. The bearings may then be cleaned by any one of

*If larger or smaller quantities than indicated are required, refer to pertinent supply manuals for applicable stock numbers.

the initial cleaning methods outlined in paragraph 16.

c. Bearings With Shields or Seals on Both Sides. Exterior surfaces of bearings having shields or seals on both sides should be wiped completely dry, using a clean cloth that has been saturated in dry-cleaning solvent and wrung dry. These bearings must not be subjected to vapor degreasing or immersed in liquid drycleaning solvent, since solvent is not satisfactorily removed from the inclosed portions of these bearings.

18. Cleaning Installed Bearings

a. Bearings can be cleaned much easier and more thoroughly when they have been removed from their housings and shafts. When removal is not possible, a light engine oil (SAE 10) 9150-292-9691 should be heated to 180° to 200 F., and flushed through the housing while the shaft or spindle is slowly rotated.

b. When grease or oil is badly oxidized and cannot be removed as prescribed in a above, a petroleum solvent such as dry-cleaning solvent or mineral spirits paint thinner may prove effective.

c. In extreme cases, use hot 100 percent paraffin base oil or a mixture of 5 percent denatured alcohol and 95 percent kerosene, or a mixture of 5 percent denatured alcohol and 95 percent dry-cleaning solvent to remove the greater part of the sludge and scale.

Caution: In such extreme cases, be sure there is no open flame in the vicinity.

When petroleum solvents, by themselves or when mixed with alcohol, are used, they should be followed by a flushing with light engine oil and drained before the lubricant is added to the housing. This will remove any of the solvents which would otherwise dilute the lubricant.

d. If the bearing is to be relubricated with grease, some of the fresh grease may be forced through the bearing to purge any remaining contaminants. This method cannot be used unless there are drain plugs which can be removed so that the old grease may be forced out. Also, operate bearings for at least 20

minutes before drain plugs are replaced, as excess lubricant will cause serious overheating of the bearing. This method of cleaning is not satisfactory for sealed or shielded bearings.

Caution: Compressed air must not be used to clean or dry cross-drive transmission 500 and 850 series bearings. Care must be taken to insure that dirt, lint, grit, or other contaminants are not introduced into the bearings during cleaning operations.

19. Drying Bearings

a. Immediately after cleaning, dry all bearings by either prepared compressed air (filtered) (method D-1); temperature controlled oven (method D-2); or infrared lamps (method D-3). Drying methods are described in TM 9-1005.

Note. Drying by wiping (method D-4) or draining (method D-5) is not authorized

b. The use of unfiltered compressed air is not authorized in bearing cleaning operations, due to the possibility of moisture and foreign matter entering the bearing. Compressed air lines must be equipped with moisture filter traps. When using filtered (prepared) compressed air for drying bearings, care must be taken to prevent spinning any of the components by force of air, since any dry particles of dirt remaining in the bearing may scratch the critical surfaces, or the spinning action may score the balls or rollers and raceways while the bearing is in an unlubricated condition. For description and application of drying methods, refer to TM 9-1005.

20. Demagnetization of Bearings

In most instances, thorough cleaning by the methods prescribed herein is adequate to remove all foreign material from bearings. However, in some instances it may be practicable to demagnetize bearings to insure that no steel particles adhere to critical surfaces due to magnetic attraction that may have developed; this may be done by the use of a commercial unit generally available locally.

AGO 2737A

INSPECTION AND SERVICEABILITY STANDARDS OF BEARINGS

21. General

a. Reconditioning of antifriction bearings is *not authorized*. Therefore, extreme care should be exercised in visually inspecting dirty bearings. As cleaning procedures progress, continue to inspect the bearings, particularly for spalls on balls, rollers, and racers. Discard unserviceable bearings.

b. Bearings without defects sufficient to cause them to be classified as "unserviceable" will be classified "serviceable" and will be made available for immediate use at the installation. Unserviceable bearings are to be disposed of as scrap. Any one of the following defects is sufficient cause for classifying the bearing "unserviceable":

- (1) Broken, cracked, or split rings.
- (2) Dented seals or shields.
- (3) Cracked or broken separators.
- (4) Broken or cracked balls or rollers.
- (5) Flaked areas on balls, rollers, or raceways.
- (6) Spalled balls, rollers, or races.
- (7) Bearings that have been overheated.
- (8) Brinelled raceways.
- (9) Scored or etched balls, rollers, or raceways.
- (10) Pitting of balls, rollers, or races.
- (11) Wear bands on critical surfaces.
- (12) Rust or corrosion on critical surfaces.
- (13) Excessive looseness of bearings due to
Note. Discretion should be used when inspecting for looseness as various ball and roller bearings are normally loose when unmounted.
- (14) Loose bearings having wear bands.
- (15) Any large or deep scratches or other appreciable defects on the rolling surfaces.

22. Common Forms of Bearing Damage

a. *General.* The most common forms of damage that occur in operation of bearings are described in b through p below. The occurrence of any forms of damage described is sufficient cause for rejecting and scrapping the bearing.

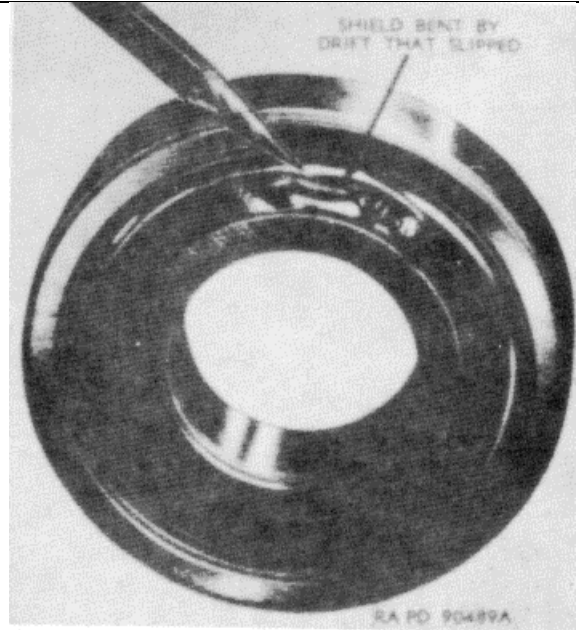

Figure 28. Dented shield.

b. *Broken, Cracked, or Split Rings.* This is often due to the wrong fit of bearings on shafts having diameters larger than specified or cocking the ring while installing or removing it.

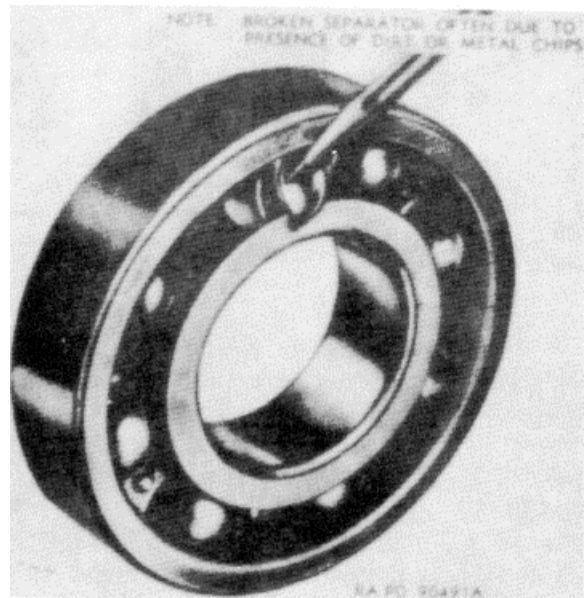

Figure 29. Broken separator.

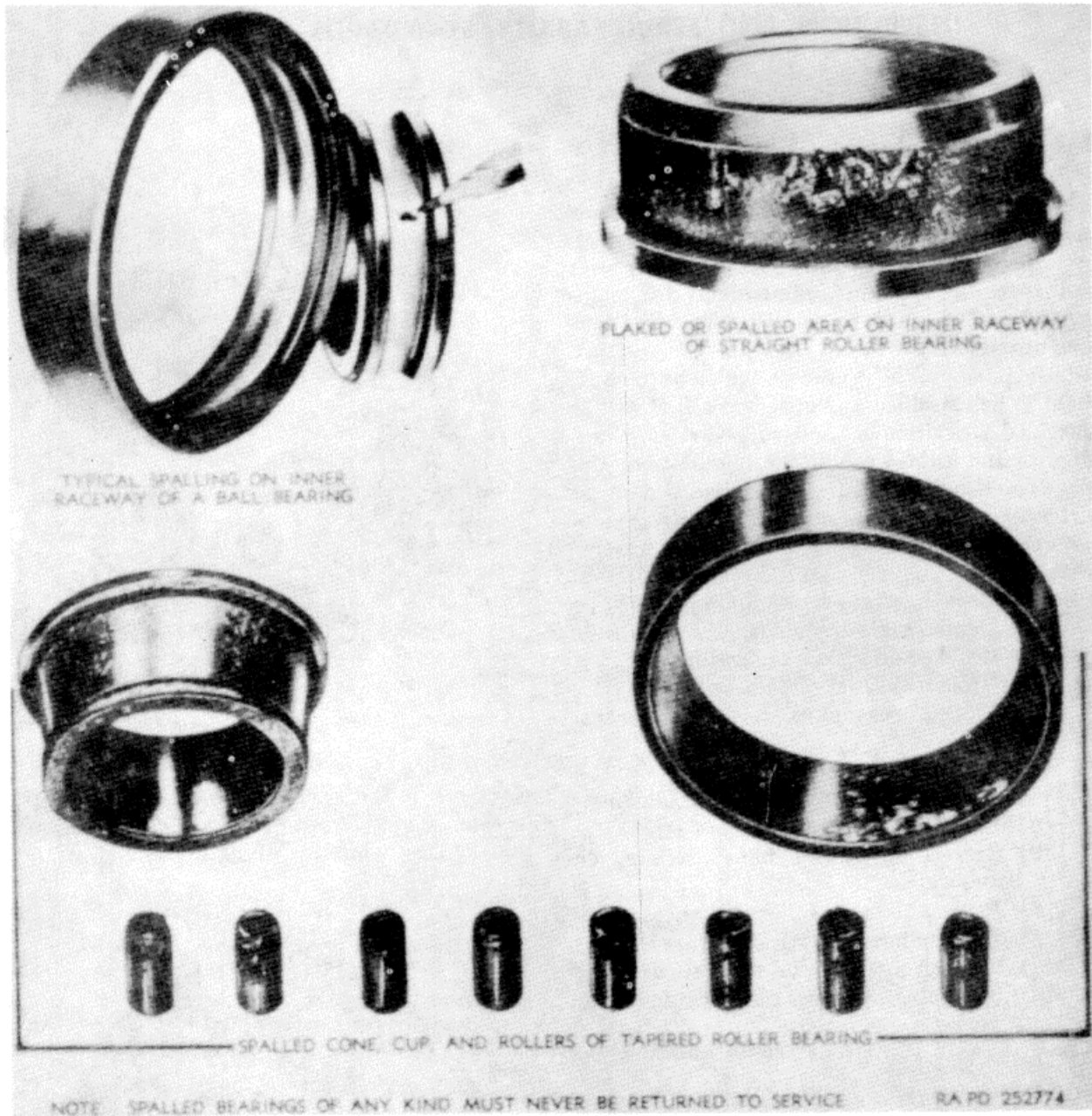

Figure 30. Flaked or spalled bearings

c. *Dented Shields or Seals.* Dented shields (fig. 28) or seals are caused by improper use of drift while disassembling.

d. *Cracked or Broken Separators.* Cracked or broken separators (fig. 29) are caused by the presence of dirt or metal chips.

e. *Broken or Cracked Balls or Rollers.* Cracked or broken balls or rollers are caused by the presence of dirt, metal chips, or overloading.

f. *Flaked Areas on Balls, Rollers, and Raceways.*

Flaked or spalled areas on balls, rollers, or raceways (fig. 30) are primarily caused by excessive overloads.

g. *Spalled Balls, Rollers, or Raceways.* Spalled balls, rollers, or raceways (fig. 30) are caused by excessive overloads.

h. *Bearings That Have Been Overheated.* Overheated bearings (fig. 31) are generally darkened to a brownish-blue or blue-black color. Overheating can be caused by either excessive speed, excessive loads,

improper lubrication, or installation

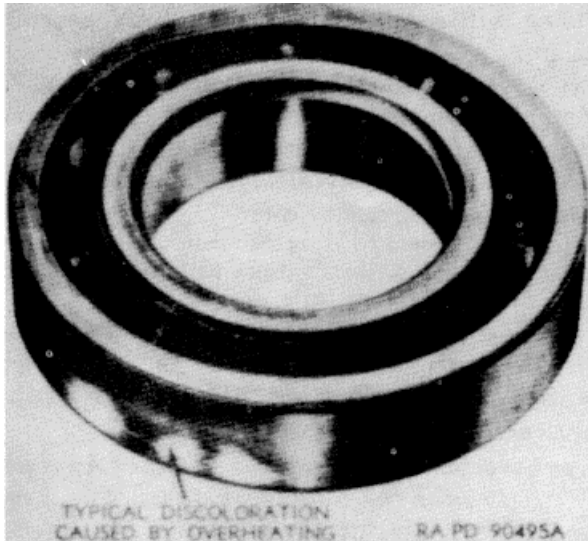

Figure 31. Overheated bearing

i. Brinelled Raceways. Brinelling (fig. 32) is caused by impressing balls or rollers into the races and appears as a series of nicks or indentations under each ball or roller. It often results when the driving force travels through the rollers instead of being applied directly to the press-fitted race. Hammer blows or sudden or excessive loads may also cause brinelling. Roughness due to brinelling may be detected by slowly rotating the bearing when the inner and outer races are tightly gripped with the finger and thumb. False brinelling

resembles true brinelling very closely in appearance but comes from entirely different causes. Bearings which are subject to vibrations, or which oscillate through a small arc instead of revolving, will show false brinelling. It is very difficult to eliminate this condition, but the removal of vibration or the use of a lubricant of low viscosity may prove effective.

j. Scored or Etched Balls, Rollers, or Raceways. Scoring or etching (figs. 33 and 34) may occur on rollers or races and is caused by dragging the roller assembly across the surface of the races in a cocked position or with a heavy load on the bearing. Although scoring may look harmless, it will cause noisy bearing operation and will eventually lead to pitting.

k. Pitting of Balls, Rollers, or Races. Pitting (fig. 35) is a form of damage which cannot always be avoided as it will eventually occur in any bearing which has operated beyond its expected life. However, there are many factors which tend to hasten pitting, such as nicking, scoring, brinelling, indenting, or the operation of bearings with excessive loads or speeds.

l. Wear Bands on Critical Surfaces. Wear bands on critical surfaces indicate excessive wear or improper rotation of the bearing.

m. Rust or Corrosion on Critical Surfaces. Rust and corrosion may be caused by handling the bearings with hands that are moist or perspiring. The fingerprint patterns are found rusted into the bearing surfaces under

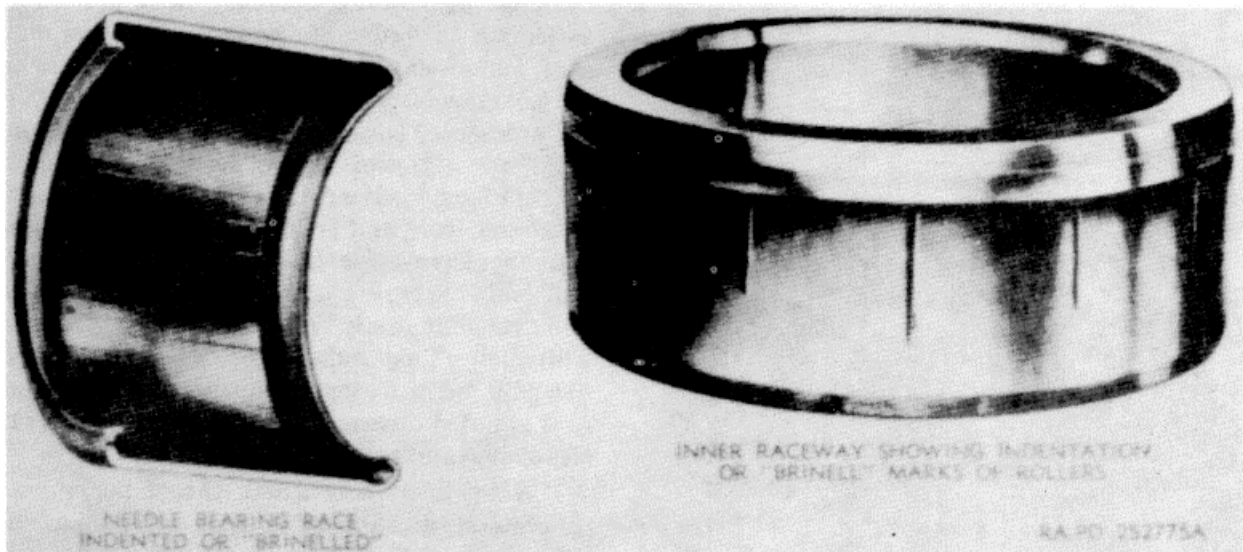

Figure 32. Brinelling

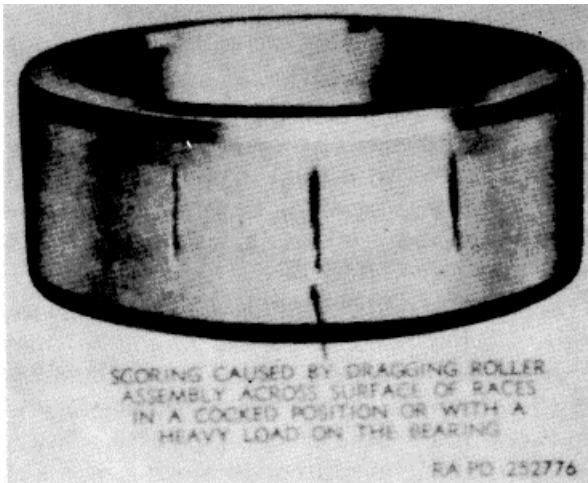

Figure 33. Scoring



Figure 34. Etching

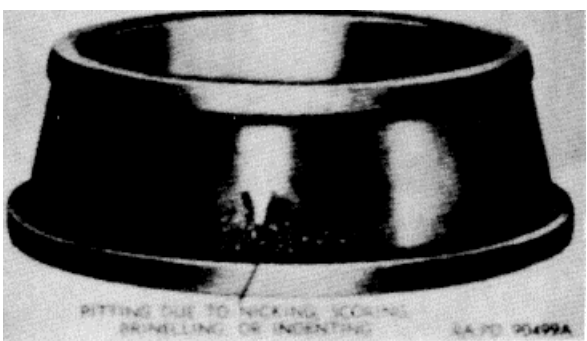

Figure 35. Pitting

the lubricant. Rust on the operating surfaces of bearings will rub off or flake during operations and pitting will result, thus causing early bearing failure.

n. Excessive Looseness of Bearing Due to Wear. Excessive looseness is due to excessive wear. A worn appearance of the balls, rollers, or raceways is nearly always indicative of excessive looseness due to wear.

Note. Care should be exercised when inspecting bearings for this defect, since various ball and roller bearings are normally quite loose when unmounted.

o. Loose Bearings Having Wear Bands. Looseness of bearings having wear bands is caused by dirt or foreign matter that has entered the lubricant or excessive wear.

p. Large or Deep Scratches or Other Appreciable Defects on the Rolling Surfaces. Any large or deep scratches or other appreciable defects on the rolling surfaces could be caused by improper bearing removal, improper mounting, dirt or metal chips, or contaminants in the lubricant.

23. Final Inspection

a. Immediately after cleaning operations, the bearings will be visually inspected to determine their serviceability.

Note. Bearings having light gray lubrication stains are acceptable, providing the surface has not been physically affected.

b. Where equipment covered in paragraph 24 is not available, inspect cleaned nonseparable bearings by holding the inner race stationary, as shown in figure 36, and rotating the outer race. Listen carefully for excessive noise while the bearing is being rotated. Feel the surfaces for excessive roughness. Watch the bearing and listen for signs of grit or roughness while it coasts to a stop. Bearings suitable for reuse will coast smoothly and freely to a stop and will not emit excessive noise. Bearings that are defective will emit excessive noise while rotating. They will transmit easily felt vibrations to the hand while being held and rotated, and will not coast to a stop but will stop abruptly. If grit or roughness is noted during rotation of the bearing, reclean, dry, and recheck.

c. When inspecting a ball thrust bearing for roughness, do not spin the bearing as described in *b* above, but place it flat face down on a clean table. Rotate the bearing slowly by exerting an even pressure

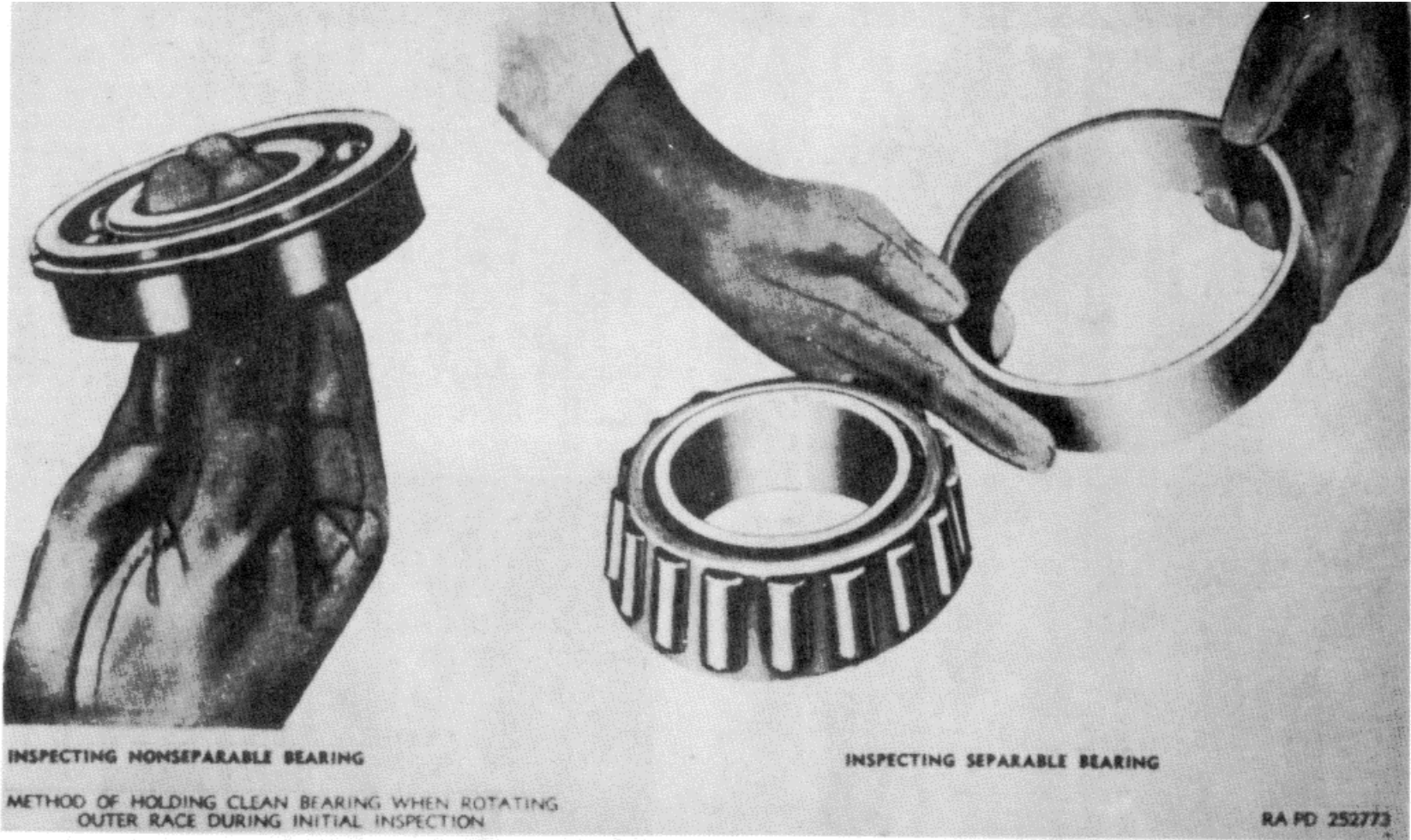

Figure 36. Final inspection of bearings

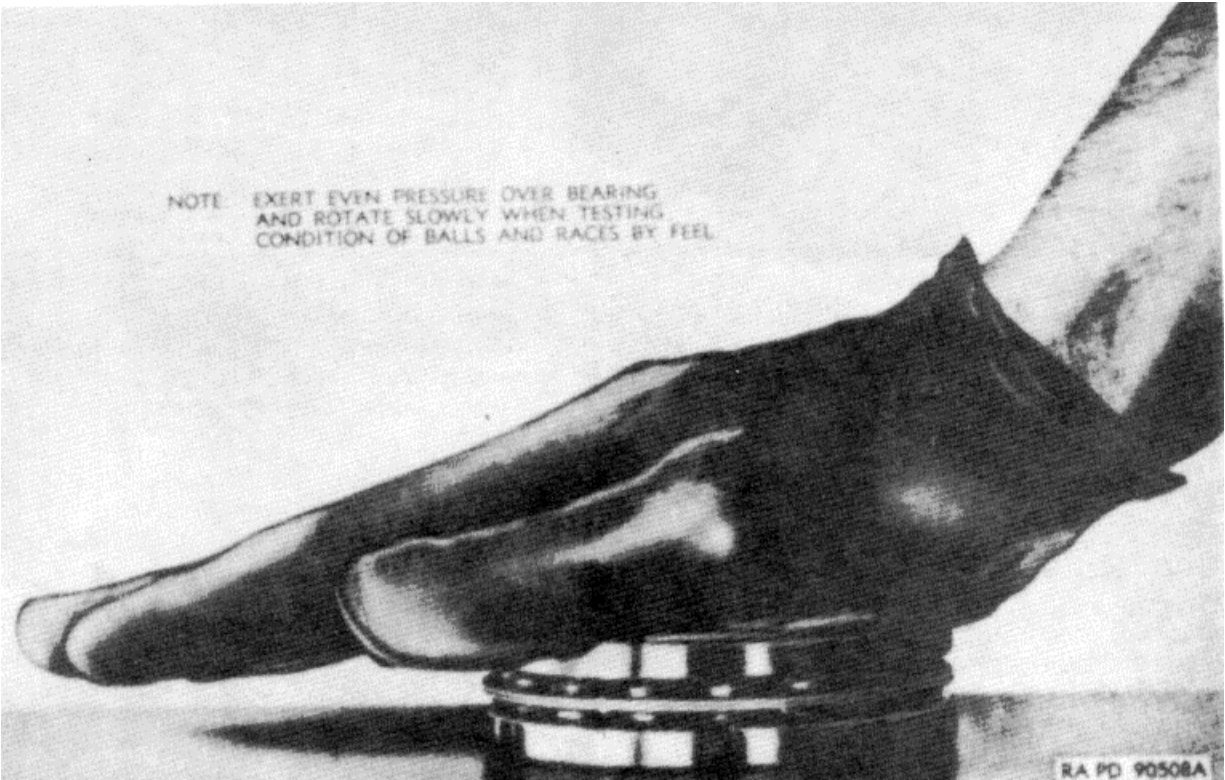

Figure 37. Testing ball thrust bearing.



Figure 38.. Visual inspection with magnifier.

and, at the same time, turning with the palm and heel of the hand as shown in figure 37. Since the bearing is without lubrication, continued rotation will score the races. Defective bearings will emit excessive noise while rotating. They will transmit easily felt vibrations to the hand while being held and rotated. As in the case of nonseparable bearings (b above), if grit or roughness is noted during rotation, reclean, dry, and recheck.

24. Four Power Floodlight Magnifier

If a 4-power floodlight magnifier is available, the final inspection will be made as shown in figure 38 to determine the extent of any imperfection.

Section VI

BEARING INSTALLATION

25. General

a. One of the most important operations to insure a properly working bearing is correct bearing installation. Regardless of all previous care a bearing may have had, it can be damaged seriously by improper installation. Even after the bearings have been cleaned and inspected, a check as outlined in b through i below must be made before actual bearing installation.

b. Check the measurement of the bearing seat diameter in all cases where there is any sign of wear or where the shaft has been ground or plated. This diameter must fall within the limits set by the pertinent technical manual and/or instruction book covering the materiel, as a loose fit will permit the bearing to move axially on the shaft, and an extra tight fit may crack the race. Make certain that the micrometer used for finding dimensions is accurate.

c. Check bearing seats on shafts to insure that they have the same degree of accuracy and

smoothness as when new. A roughly ground bearing seat will have the tops of the grinding ridge peened down and will cause looseness after the bearing has been operating a short time. Hand finishing with emery or crocus cloth must be done very carefully to avoid high and low spots. In addition, remove all burrs and sharp corners from shaft ends over which rings must pass.

d. Shafts having the bearing seat badly scored or worn must be reground before being placed in service, otherwise, the inner race may be distorted and the bearing internal clearance reduced. The regrinding of the bearing seat may reduce the diameter to a size smaller than that required to maintain a tight fit. In such cases, the bearing seat may have to be built up by metal spraying (fig. 39), or by applying a sleeve to the shaft with a heavy press fit. The shaft or sleeve must then be remachined to the required size.

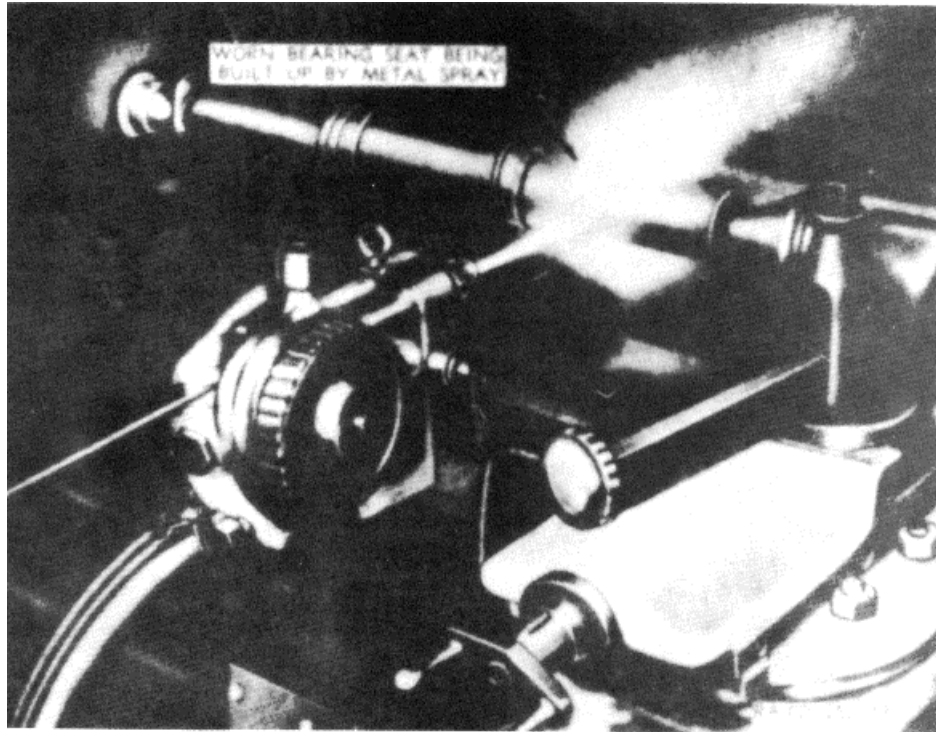

Figure 39. Metal spraying worn bearing seat.

AGO 2737A

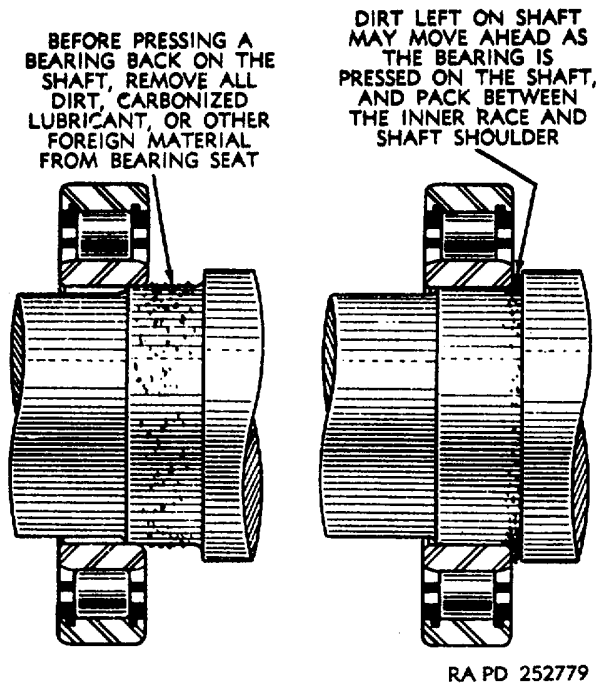

Figure 40. Cleaning of bearing seat.

e. Before pressing a bearing back on the shaft, clean the bearing seat of all dirt, carbonized lubricant, or any other foreign matter. If the bearing seat is not cleaned, the dirt will move ahead as the bearing is

pressed on the shaft and pack between the inner race and the shaft shoulder, causing improper adjustment of the bearing and possible scoring of the shaft and the bearing bore (fig. 40). If the dirt is later dislodged, the end thrust on the bearing may cause an endwise movement of the shaft and consequent misalignment of other parts.

f. Give particular attention to the removal of fins, core sand, and other foreign matter from the interior of castings. After cleaning, paint the casting to close the casting pores. Very often the cleaning of inaccessible cored oil pockets and the undersides of lugs is neglected and from these sources abrasive dirt enters the bearings. Inspect oil holes to make sure they are not plugged.

g. After the bearing seat and the bearing bore have been thoroughly cleaned, apply a lubricant containing graphite, zinc, -or lead for best results (fig. 41). The lubricant aids in pressing on the bearing and helps prevent the formation of rust and scoring at the press fit. The lubricant also assists in any later removal of the bearing.

h. After removal of all burrs and splinters with a fine file and crocus cloth, clean and lightly oil the shafts, bearing housings, keyways, and splines. The unit will then be ready for installation.

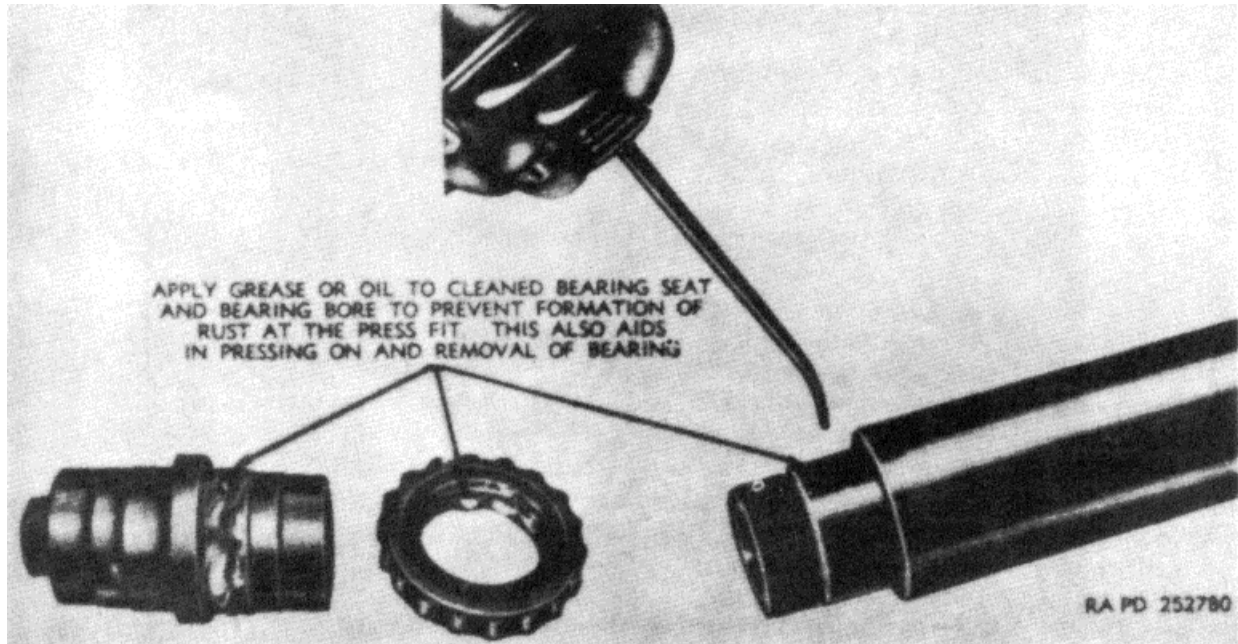

Figure 41. Lubrication of bearing seat and bearing bore.

AGO 2737A

i. The proper tools and correct handling must be used during installation, because bearings are often damaged during installation of the unit if the proper precautions listed in (1) through (9) below are not followed.

- (1) Do not remove a new bearing from its package until ready for assembling.
- (2) Start bearings on shaft with rounded edge of internal race foremost.
- (3) Apply the driving force directly through the race to be pressfitted, making sure that pressure is directed straight and square.
- (4) Never hammer directly on races or rollers and never use a wooden or soft metal mallet, as chips or splinters may enter the bearing.
- (5) Use many light quick taps rather than a few heavy ones.
- (6) Be sure that the accessories and fixtures used in driving have straight square ends.
- (7) Drive races solidly up against shoulder of shaft and housing.
- (8) Clean tools and clean surroundings are essential, if damage to the bearing is to be avoided.
- (9) Never use outer races of bearings as housing bore gages, because of their relative flexibility. New bearings must never be used as housing bore gages, because dirt may enter into them.

26. Bearing Installation by Arbor Press

a. General.

- (1) The arbor press (fig. 42) provides one of the best means of installing bearings and races and should be used, if available.
- (2) Lay the bearing on the press base plate having a slot or hole slightly greater than the bearing bore. Press the shaft into the bearing, supporting the inner race of the bearing on the base plate. Press bearing on straight and square (fig. 43) starting it true on the shaft and not cocked; otherwise scoring of the shaft or splitting of the race may result. Press only on the bearing race which takes the tight fit. Press the bearing until it is seated against the shaft or housing shoulder. Be sure that the base plate supports the inner race

and does not scrape the shaft or threads (fig. 42).

- (3) Accessory equipment, such as steel drive plates, pipe, or tubing which will transmit the pressing force accurately through the press fitted race, should be used whenever necessary.

b. *Pressing Through Races* (fig. 44). Apply the force required to drive bearings on shaft or into housings to the face of the proper bearing race. Where bearing or bearing parts are installed on shafts, apply the force evenly and squarely to the face of the inner race, and where bearing or bearing parts are installed in housings, apply the force evenly and squarely to the face of the outer race. If the force is directed upon the wrong race or against the rollers, cage, or snaprings, damage in the form of brinelling, bending, or fracture will result.

27. Bearing Installation by Bearing Pullers

a. Certain types of bearing pullers are used to drive inner races on shafts (figs. 12-14).

b. They are used with a split collar placed behind the bearing to distribute the pressure evenly over the bearing face and to carry the pressure through the inner race rather than through the outer race and rollers.

c. The use of these type bearing pullers is limited to inner race assembly.

28. Bearing Installation by Driving

a. Use of Hammers.

- (1) Hammers or mallets must never be used by themselves to drive bearings or bearing parts. They may be used with accessories, such as drive blocks and pipe or tubing described in b and c below.
- (2) Hammering directly on races is the surest way of injuring the bearing because it produces brinelling, race cracking, or damage to the cage and snaprings (fig. 16).
- (3) Hammering directly on races is also a hazard to the operator, since the hard bearing race may splinter with possible injury to the eyes or face.

b. Installing Bearings With Drive Blocks.

- (1) Drive blocks (fig. 19) are among the most convenient means of installing a bearing on a shaft or into a housing.

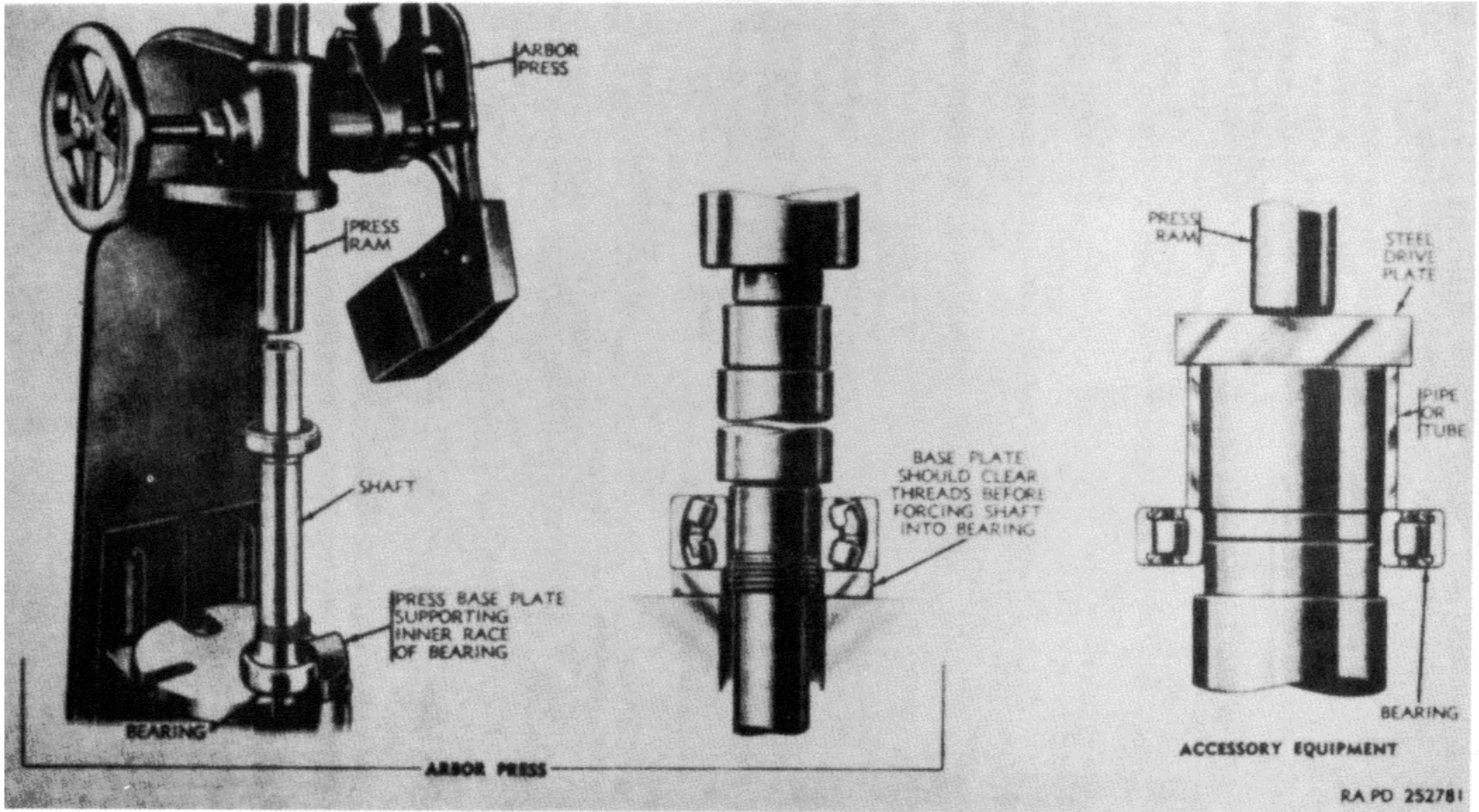

Figure 42. Installing bearings and races by arbor press.

PRESSURE SHOULD BE DISTRIBUTED AS UNIFORMLY AS POSSIBLE OVER ENTIRE ENTIRE FACE OF THE RACE

CONCENTRATING THE LOAD ON ONE SIDE IF THE RACE WILL CAUSE COCKING AND RESULT IN SCORING THE SHAFT OR SPLITTING THE RACE

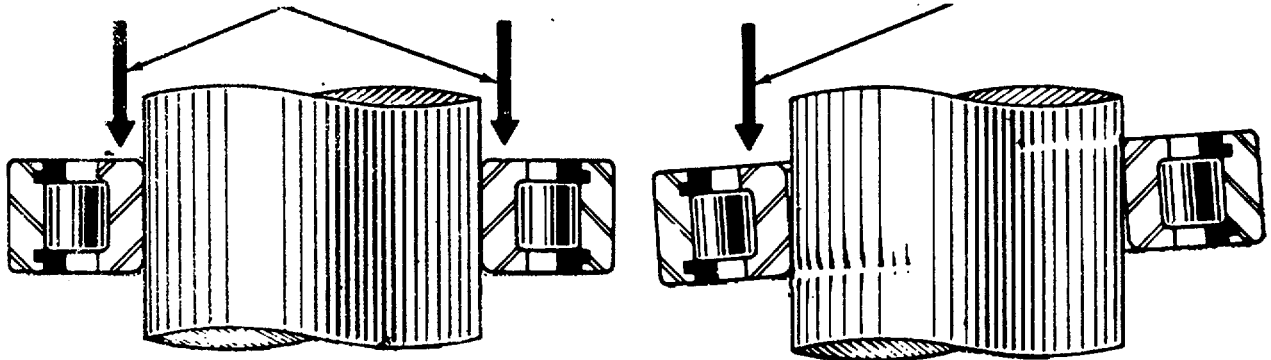

Figure 43. Pressing bearing on shaft straight and square.

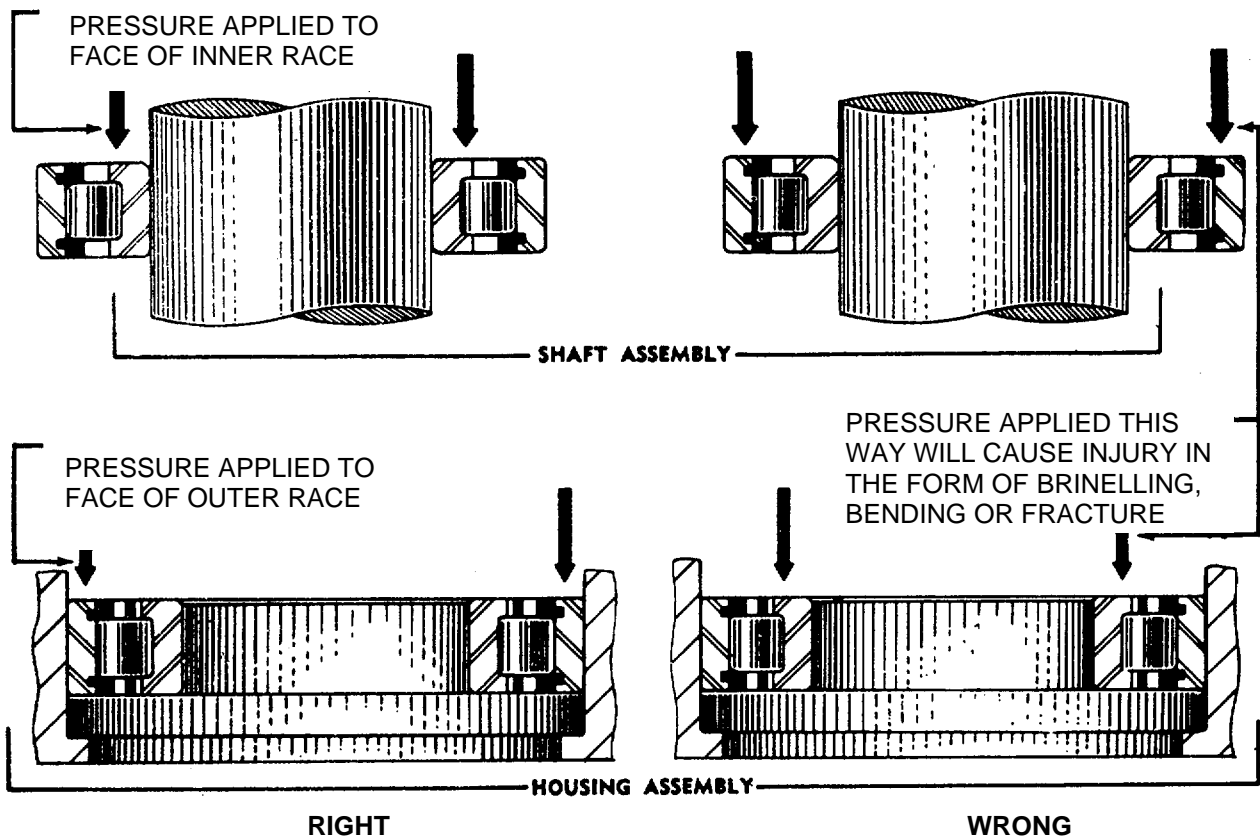
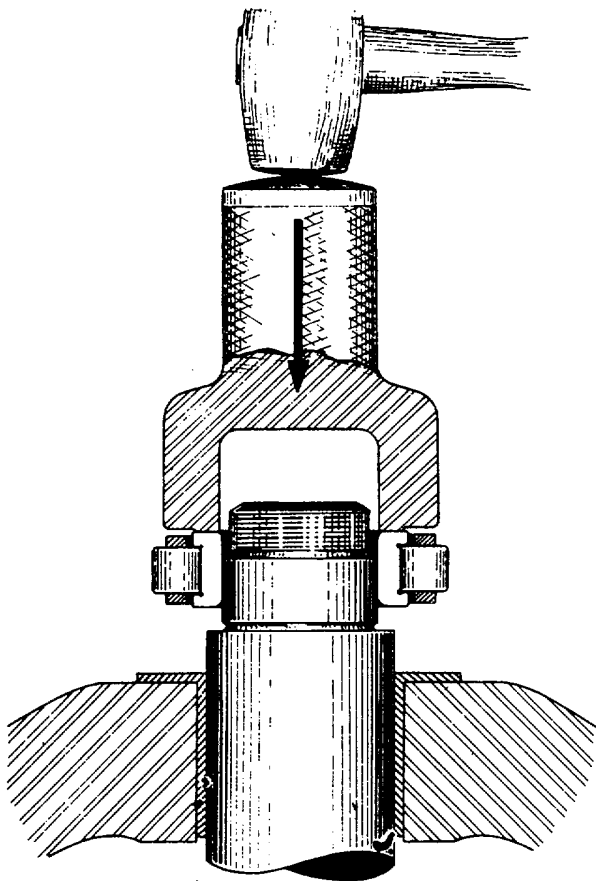

Figure 44. Pressing through races

RA PD 90459A



NOTE

AFTER BEARING IS ON FAR ENOUGH TO ALINE ITSELF WITH SHAFT, DRIVE TO FIRM SEAT AGAINST SHOULDER

RA PD 90465A

Figure 45. Installing bearings with drift or bearing installer.

They are simple to construct and are especially useful where the operation is repeated many times.

- (2) Drive blocks can be used for either outer race, inner race, or complete bearing installation. They must be so constructed, however, that the force travels only through the pressfitted race and that the race is brought up snug against the shoulder or other stop provided.

c. Installing Bearings With Pipe or Tubing.

- (1) Pipe or tubing (figs. 17 and 18) are used

to install races or bearings in the same manner that they are used to remove them (par. 12b and c).

- (2) Pipe or tubing can be used in conjunction with an arbor press as well as with a hammer.
- (3) The force is distributed over the end of the tube by means of a steel block or cap.

d. Installing Bearings With Drift or Bearing Installer (fig. 45). When the end of the shaft is flush with the bearing, use a drift or bearing installer with a flat end. When the shaft projects beyond the end of the bearing for a short distance, use a drift or bearing installer with a counterbore. Tap lightly at first to make sure the bearing or race goes on square and does not scrape or bur the bearing seat. Make certain the bearing is tapped to a firm seat against the shaft shoulder.

e. Cup and Cone Drivers (fig. 46).

- (1) When assembling bearing cups and cones in housings and on shafts, use proper fixtures so bearings will not be damaged.
- (2) Care must be taken not to drive against the bearing cage or the tapered inside diameter of the cup. The fixtures (fig. 46) will insure driving against the end of races where no damage will be done and the least amount of effort will be required to seat the bearing. Hard steel bars must not be used to drive on bearings or remove bearings, as the hard bars or drifts will nick or otherwise damage the bearings.

29. Bearing Installation by Heating

a. General.

- (1) Large bearings, precision bearings, and bearings which must be pressed over a considerable length of shaft or cover a tight fitting bearing seat may require heating while being installed on shafts.
- (2) Take extreme care to insure that bearings are never heated above 2500 F. If the bearings are heated above this temperature they will begin to draw or soften.
- (3) When bearings are heated for installation, check the heated part after it has cooled to see that it has been seated properly against the shoulder.

Note. The bearing must be clamped solidly against the shoulders, as there is a tendency for the bearing to pull away from the shoulder as the bearing cools.

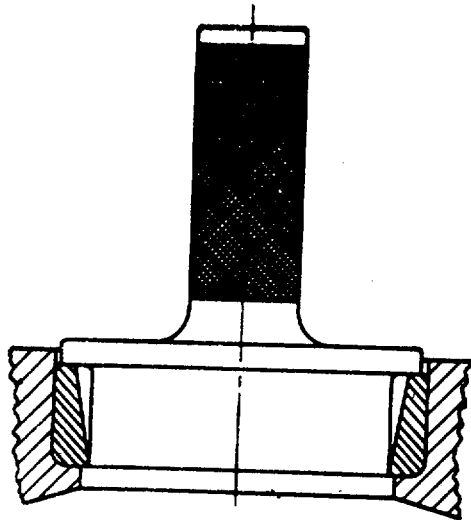

DRIVING CUP FROM THE SMALL END

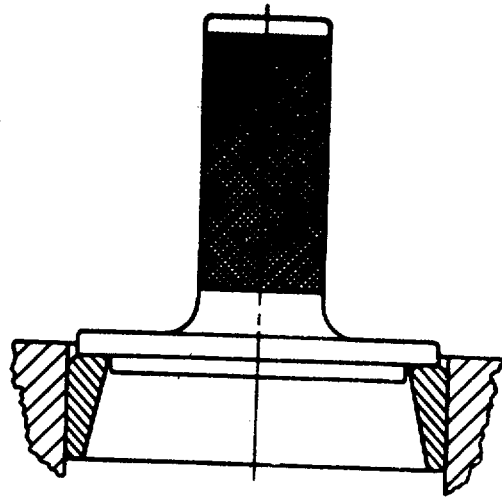

DRIVING CUP FROM THE LARGE END

CUP DRIVERS

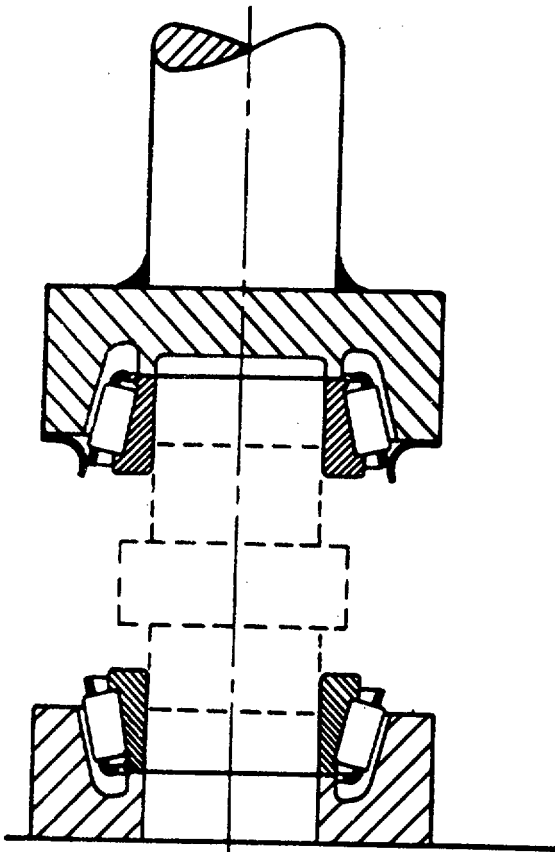

PRESSING TWO CONES ON ONE
IN A SINGLE OPERATION

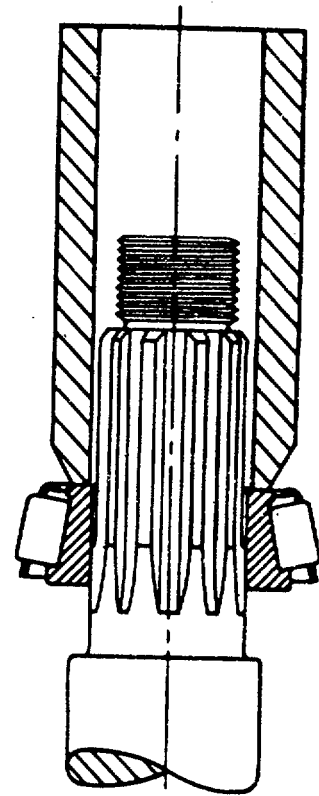

DRIVING A SINGLE
CONE ON A SHAFT

CONE DRIVERS

RA PD 252785

Figure 46. Driving with cup and cone drivers.

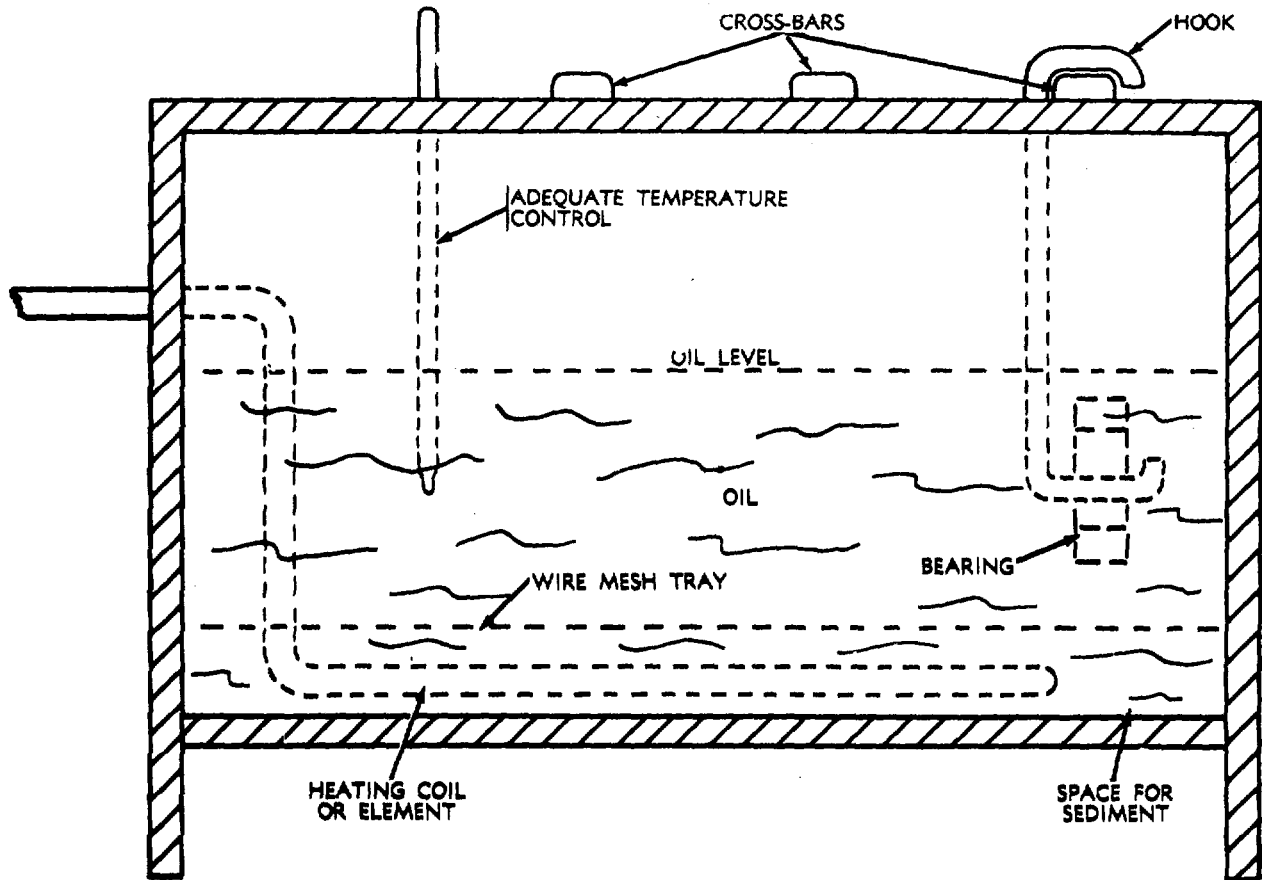

NOTE: SUPPORT BEARING ON WIRE MESH TRAY OR HOOKS WELL AWAY FROM BOTTOM OF TANK. TEMPERATURE OF OIL MUST NOT EXCEED 250° F,

RA PD 252787A

Figure 47. Heating bearings in temperature controlled oil tank.

b. Heating Bearings in Oil (fig. 47).

- (1) This operation consists of heating the bearing or inner race in a temperature-controlled oil tank containing heated clean engine oil (SAE 80) 9150-2929693 (55-gal. drum)* at a temperature of between 2000 to 2500 F. This expands the inner race sufficiently so that it can slip over the shaft to the bearing seat, thereby avoiding use of excessive force and damage to the ground surface of the shaft.
- (2) Work the bearing onto the shaft straight and quickly, because if it should become cocked or stuck it may cool in that position and will have to be pulled off and the operation repeated.

Caution: Do not exceed a temperature of 2500 F. or leave the bearing in the oil longer than necessary

to obtain the required temperature.

- (3) Never place bearings on the bottom of a tank; suspend them by hooks or place them on a wire mesh tray (fig. 47), because they must be heated uniformly and must be free from sludge or dirt which accumulates at the bottom of the tank.

c. Heating Bearings by Electric Lamps. Electric lamps may also be used to expand the races. A shelf-like structure is arranged so that when the bearing rests on it the inner race bore surrounds the large section of the bulb. The burning lamp heats up the race, expanding it, while permitting the outer race to remain cool for convenient handling.

____*If larger or smaller quantities than indicated are required, refer to pertinent supply manuals for applicable stock numbers.

d. *Heating Bearings by Infrared Lamps.*

- (1) One of the best methods of heating bearings is with infrared lamps. The heat can be regulated by the number of lamps used and the distance of the lamps from the bearing. This method assures maximum cleanliness because the bearing can be heated in its original container.
- (2) Where large quantities of bearings are to be heated, place the bearings on a shelf between batteries of infrared lamps and reflectors. The bearings are moved along the shelf regularly or are permitted to remain there until the required temperature is reached.

e. *Heating Bearings by Hot Air* (fig. 48)..

- (1) When hot air is used instead of oil to expand races on large bearings, heating may be done in a small electric furnace or in a muffle type gas-fired furnace. Service bearings may be retained in their original cartons. In this way, the bearings are kept fully protected from dirt until actually ready for installation.
- (2) The temperature of the air in the furnace must never exceed 250° F.

f. *Induction Heating.* Induction heating of bearings must never be used, as surface temperatures will get too high and draw the bearings.

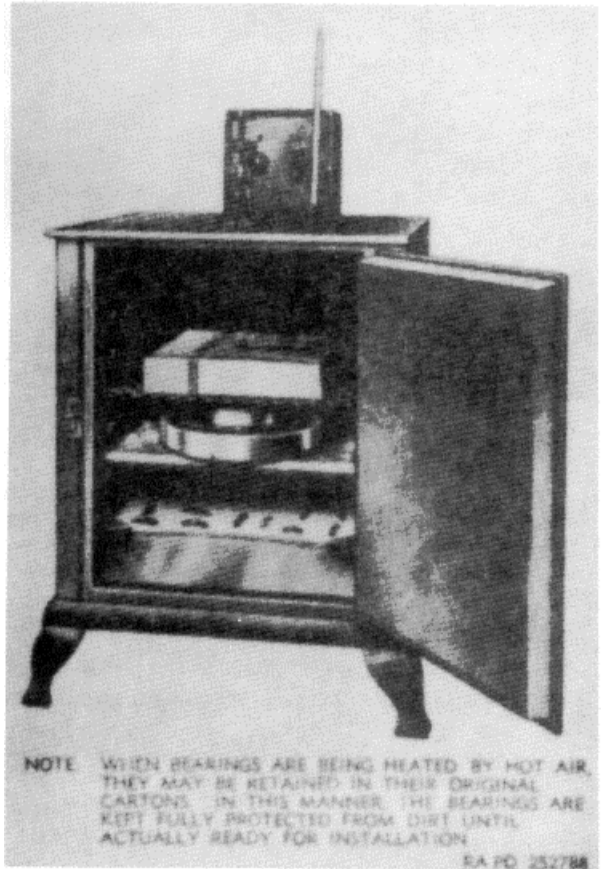

Figure 48. Electric hot air furnace.

30. Bearing Installation by Freezing

a. The bearings may be installed by cooling the bearing journal in crushed dry ice (carbon dioxide snow) until the diameter is reduced 0.001 inch.

b. This method is preferable due to the fact the bearing is not handled except when actually being installed.

c. Basically this process consists of wrapping a cloth filled with crushed dry ice around the bearing journal. After the diameter has been shrunk, the cloth is removed, and the bearing is installed.

d. Extreme care must be used to make sure that any moisture or condensation that results from applying dry ice to the journal is removed.

e. This procedure is important, because if all moisture is not removed corrosion will result between the shaft and bearing bore, and it will be difficult to remove the bearing at the next overhaul without marring the shaft.

f. Remove moisture by thoroughly wiping the shaft

journal with a dry, lint-free cloth before installing the bearing.

g. Where cups are to be assembled in hubs or housings with a pressfit, particularly in aluminum or magnesium hubs, they can be shrunk in a deep-freeze unit (fig. 49) or an alcohol bath which is cooled with dry ice. In some cases, it is also necessary to heat the housing, in addition to cooling the bearing cup, to permit the cup to slip into place readily. Be sure to remove any moisture or condensation from the bearing cup before installing.

31. Final Installation

a. If none of the heating (par. 29) or freezing methods (par. 30) are available for installation of bearings, the methods described in paragraphs 26-28 must be used. Observe precautions noted in paragraph 25*i* for final installation of bearings. When pressing a bearing

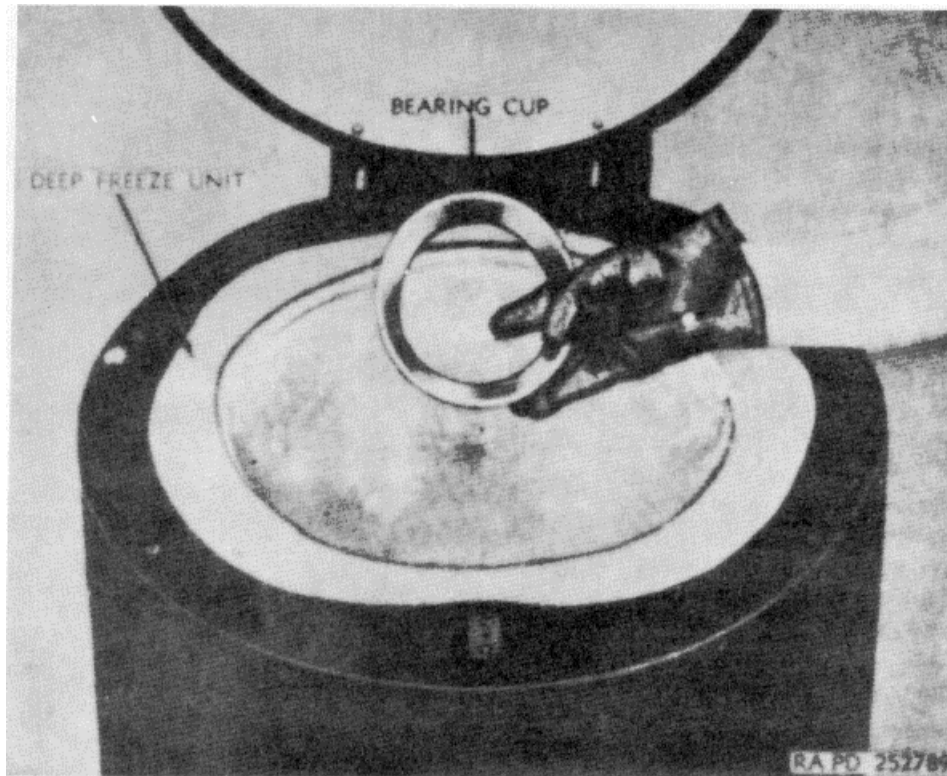

Figure 49. Deep freeze method of shrinking bearing cup.

onto a shaft, it is important that force be applied to the inner race (fig. 44), and when pressing a bearing into a housing, force must be applied to the outer race (fig. 44).

Caution: Do not leave bearings in partial assemblies uncovered, as harmful dust or dirt will collect if left standing too long. If bearings in partial assemblies are to be left several hours or overnight, lubricate and cover them with clean cloth or paper until ready to complete installation (fig. 50).

b. Before the final installation has been completed, check the entire unit for alinement. Some common causes for misalinement are outlined in (1) through (5) below.

- (1) Out-of-line housing.
- (2) Tilted housings or out-of-square housing shoulders.
- (3) Out-of-square or inadequate shaft shoulders.
- (4) Improper corner fillets.
- (5) Housings or shafts not thoroughly cleaned.

c. After final installation, the unit should run free from any surging or whining under no load testing.

Certain characteristic noises that usually predict trouble are outlined in (1) through (3) below.

- (1) Surging or whining indicates that the bearings are preloaded by cramping. Axial preload can result from any of the following conditions:
 - (a) the distance between the shaft shoulders is such that the distance between the outboard faces of the bearings is greater than the distance between rabbets in the installed end bells.
 - (b) When end bell bearing seats are undersized or tapered causing axial cramping during assembly.
 - (c) When preloaded by improper use of shims.
 - (d) When the design of the bearing does not permit, or compensate for, linear expansion.
- (2) When there is excessive vibration, usually caused by unbalanced rotors or fans. Note that bearings can contribute to vibration if the bearing seat in the housing is oversized or if the

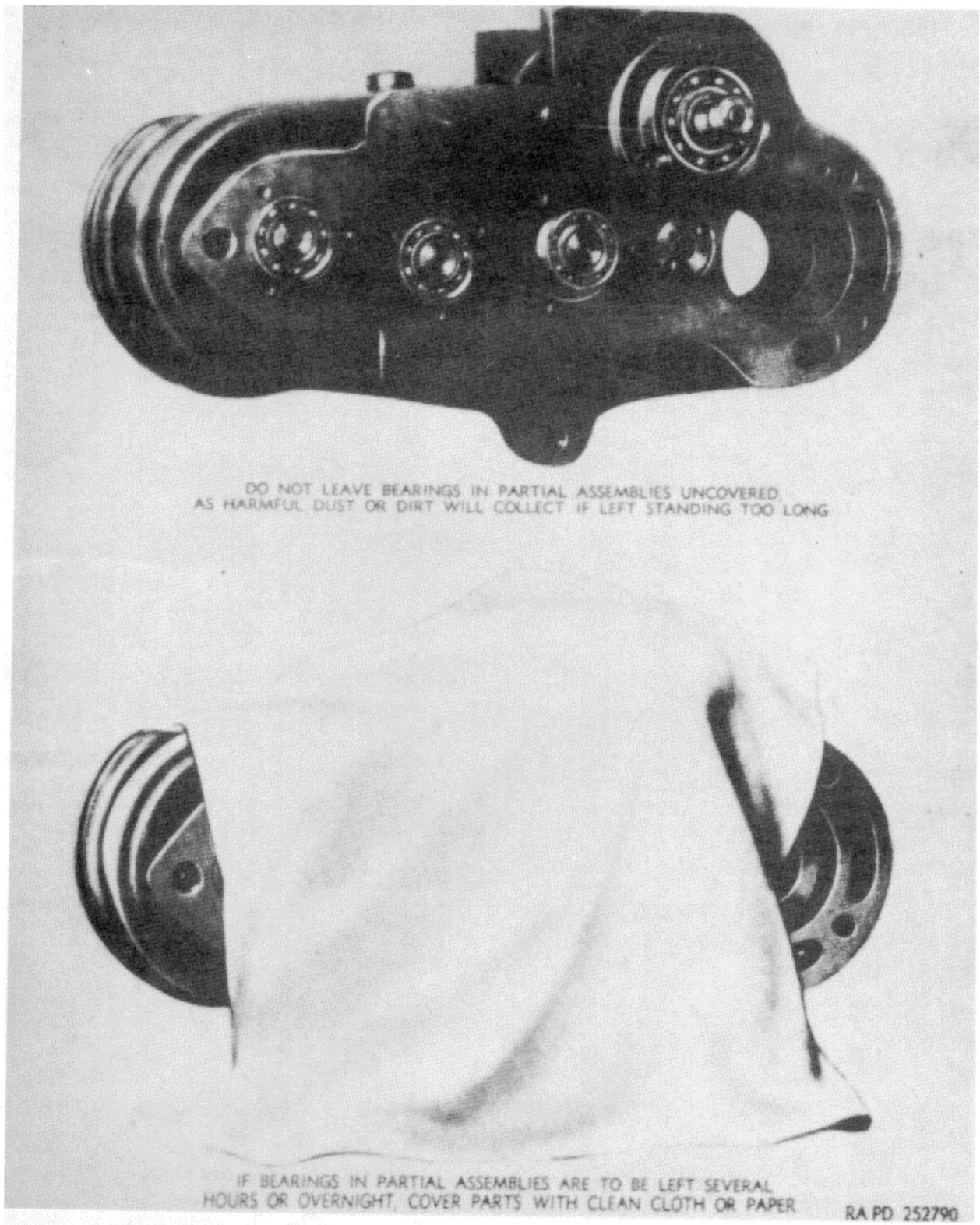

Figure 50. Partial assemblies.

bearing seat on the shaft is undersized.
(3) When there is contamination in the bearing or in the lubricant from

mishandling, thus causing intermittent snapping and grinding noises.

AGO 2737A

Section VII

BEARING ADJUSTMENT

32. General

Certain types of ball bearings and dual purpose bearings with tapered or barrel-shaped rollers require adjustment at assembly. If a bearing is set too tight, it will heat up and possibly fail. Loose bearings cause pounding which in front wheels, for example, may crack the spindle, cause shimmy, make the vehicle hard to steer, or cause excessive wear of tires. Some typical examples of bearings set with free running clearance or end play and some set with preload are outlined in paragraphs 35 through 45. Where the adjustments detailed herein differ from those prescribed by the pertinent equipment technical manual, the latter will govern.

Note. Never install bearings in damaged housings or on damaged shafts or spindles.

33. Adjusting Devices

a. Typical adjusting devices are shown in figure 51. There are many others which are, in general, variations of these. The most common adjusting device consists of a slotted hexagon nut and a cotter pin on a threaded shaft (detail A, fig. 51). This is a simple and inexpensive method for bearing adjustment and is commonly found on automotive front wheels.

b. The adjusting device shown in detail B, figure 51, uses two standard locknuts and a tongued washer. The inner nut is pulled up until there is a binding on the bearings when rotated, then backed off sufficiently to insure proper running clearance after the outer nut is tightened. This adjusting device is used in full-floating rear axles and some front wheel applications. It provides a much finer adjustment than the slotted hexagon nut.

c. In the adjusting device shown in detail C, figure 51, shims are used between the end plate and the housing. The shim pack selected is the one which will give the proper bearing running clearance recommended for the particular application. The end plate is held in place by cap screws which can be wired as shown or locked with lockwashers. This method of adjustment is used where press-fitted cones are used with loose-fitted

cups. This type of adjusting device is used in transmissions and axle carriers.

d. The threaded cup follower adjusting device is shown in detail D, figure 51. The follower is locked by means of a plate and capscrews. The plate fits between the lugs of the follower. This type of adjusting device is used in automotive differentials.

e. The cone spacer adjusting device is shown in detail E, figure 51. The cones are clamped against the shoulder on the shaft with an end plate and cap screws. This type of adjusting device is used on propeller shafts. There are two types of cone spacers, one is a solid ground ring and the other has oil holes as shown in figure 52. Cone spacers are tailor made for one particular bearing and cannot be interchanged with any other bearing.

f. Cup spacers, like cone spacers, are furnished with or without oil holes depending upon the application point (fig. 52).

34. Front Wheel Bearing Adjustment

a. Relieve the bearings of all load by raising each wheel from the ground.

b. Remove the hub cap and cotter pin.

c. Draw up the adjusting nut (fig. 53) while revolving the wheel in both directions, until a slight binding is felt which indicates that all surfaces are in contact. Then back off the adjusting nut 1/6 to 1/4 turn or sufficiently to allow the wheel to rotate freely within limits of 0.001 to 0.010-inch end play.

d. Lock the adjustment at this point.

e. Do not confuse tight grease retainers or brakes for tight adjustment and do not confuse a loose steering knuckle bolt for loose adjustment.

35. Front Wheel Drive Bearing Adjustment

a. After the vehicle is jacked up so that the wheel clears the ground or floor, the bearings are adjusted by rotating the wheel in both directions while taking up on the adjusting nut (detail A, fig. 54).

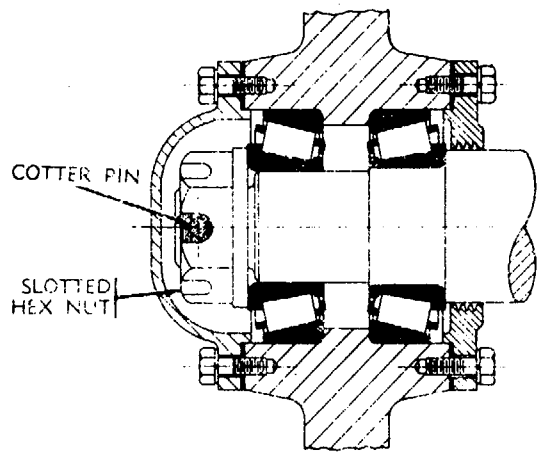

COTTER PIN
SLOTTED HEX NUT

DETAIL A
SLOTTED HEX NUT AND COTTER PIN ADJUSTING DEVICE

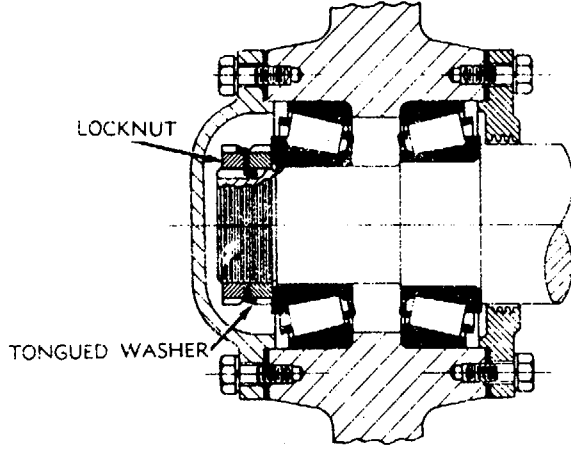

LOCKNUT
TONGUED WASHER

DETAIL B
TWO STANDARD LOCKNUTS AND TONGUED WASHER ADJUSTING DEVICE

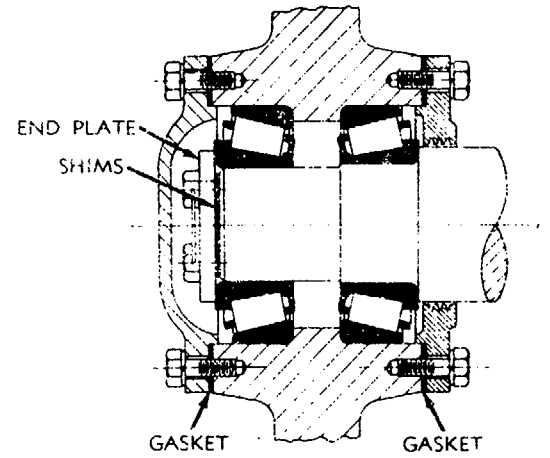

END PLATE
SHIMS
GASKET GASKET

DETAIL C
SHIMS USED AS ADJUSTING DEVICE

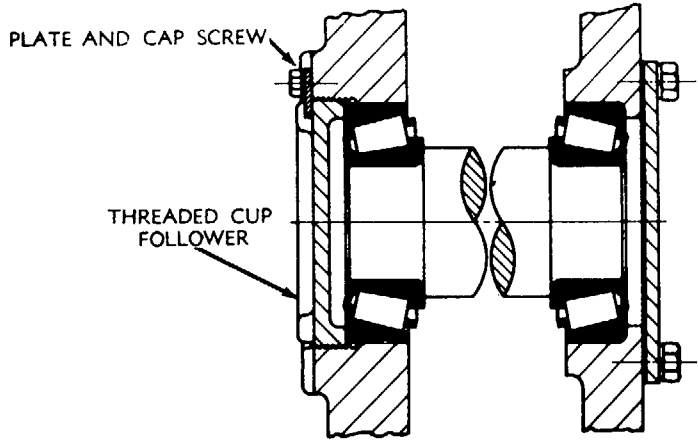
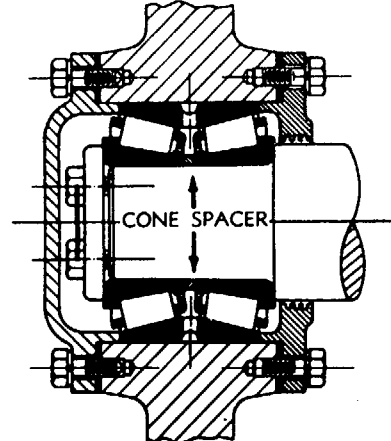

PLATE AND CAP SCREW
THREADED CUP FOLLOWER

DETAIL D
THREADED CUP FOLLOWER ADJUSTING DEVICE



CONE SPACER

DETAIL E
CONE SPACER ADJUSTING DEVICE

RA PD 252791

Figure 51. Adjusting devices.

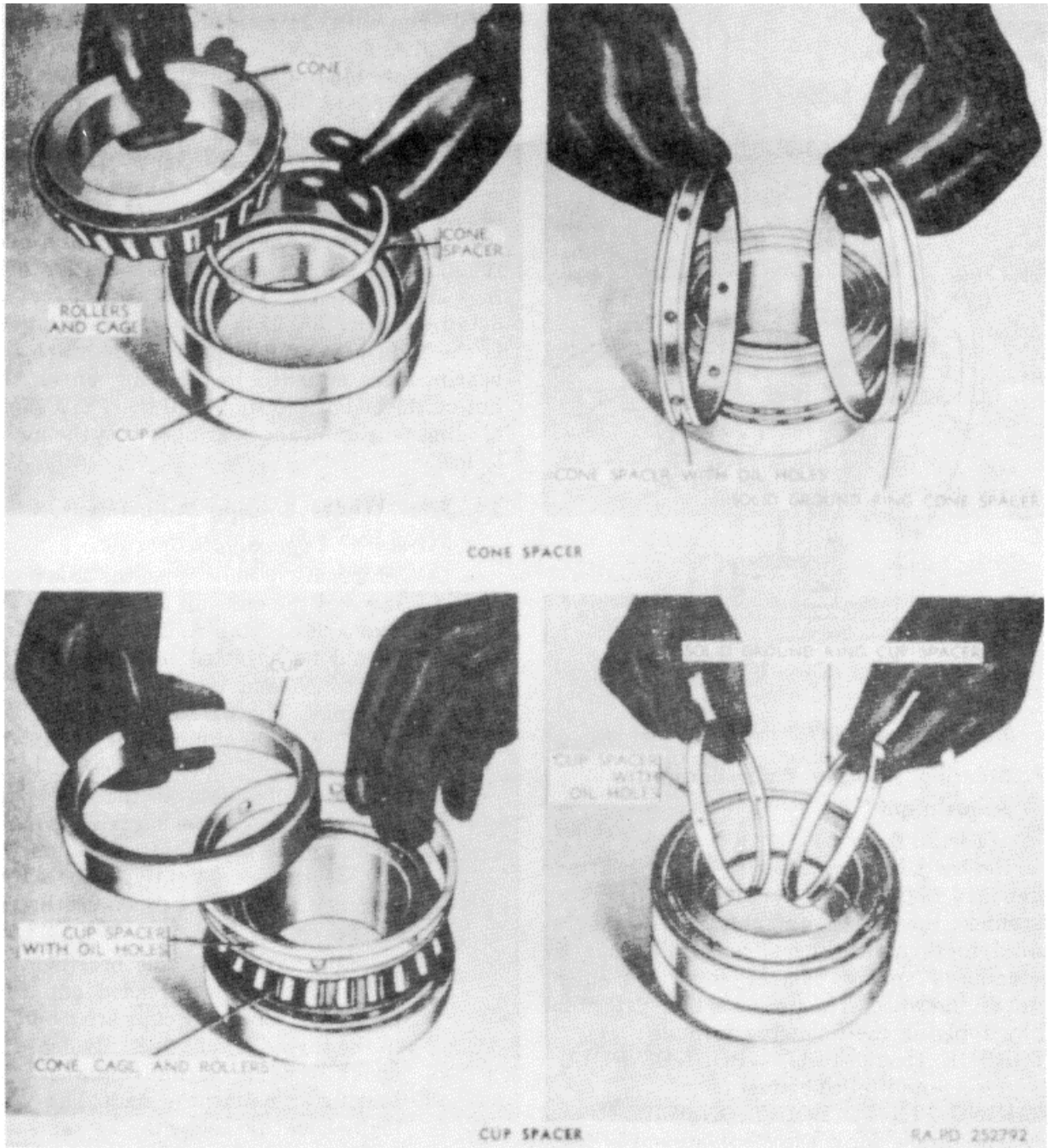

Figure 52. Cone and cup spacers.

b. When a binding is noted in the wheel, the nut is backed off 1/6 to 1/4 turn or sufficiently to allow the wheel to rotate freely or hold within the limits of 0.001 to 0.010-inch end play in the bearings after the locknut is tightened.

c. The locknut may change the adjustment due to looseness of nut on threads, so allowance must be made for this change.

d. When adjustment is completed, bend the flanges of the lockwasher over the flats of both nuts.

36. Trailer Axle Bearing Adjustment

The bearing adjustment on trailer axles are similar to those of front wheels and the method of adjustment is the same (figs. 53 and 54).

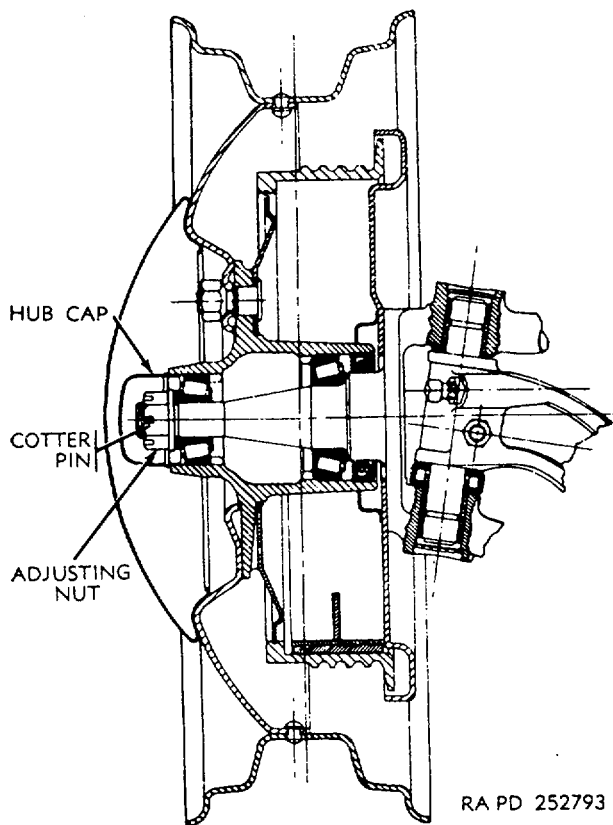

Figure 53. Standard front wheel adjustment.

37. Steering Knuckle Pivot Bearing Adjustment (detail B, fig. 54)

a. Before adjusting steering pivot bearings (standard radial thrust type), raise the wheel, disconnect the tie rod, and check the torque required to turn the knuckle. This is done by fastening a spring balance to a convenient point on the wheel. The torque is then determined by applying the following formula:

$$\text{TORQUE (pound-feet) = POUNDS PULL} \\ \text{multiplied by feet from} \\ \text{KING PIN TO POINT ON WHEEL}$$

b. The torque for correct adjustment is from 20 to 26 pound-feet. This may vary with some designs, in which case the manufacturer's recommendation should be followed.

c. Should the adjustment be found too loose, take off the bearing adjusting cap and remove shims until the desired adjustment is obtained.

38. Steering Gear Bearing Adjustment

a. There are two types of adjustments generally used, the shim and/or threaded nut (fig. 55).

b. When shim adjustment is used as shown in detail A, figure 55, remove sufficient shims to give a slight binding or tension on the bearings. A good standard practice for bearing torque is about 2 pounds pull at the rim of the steering wheel, with the drag link disconnected.

c. When the threaded nut adjustment is used as shown in detail B, figure 55, adjust the bearings to the same torque as when shims are used, then lock the nut. On some mountings the bearings are mounted on follower pins as shown in detail C, figure 5.5. This type of steering gear is the twin cam and lever type, in which the bearings are adjusted by drawing up on the nut on the end of the stud until there is a slight binding tension in the bearings, then the nut is locked.

39. Rear Wheel Bearing Adjustment

a. Fixed Hub Type, Single Bearing.

(1) Shims are used between the axle housing and the end cap on passenger car rear axles (detail A, fig. 56). Bearings should be adjusted to give 0.005 to 0.008-inch end play in the two axle bearings. The axle drive shafts butt together in the differential center and care should be taken to get an equal thickness of shims at the outer end of each axle. When checking adjustment, rotate axle shafts and tap the end of the axle lightly with a lead hammer to insure proper seating of the bearings.

(2) In some cases, the axle bearings are adjusted through threaded cup containers. The bearing cups are mounted in the threaded container. By drawing up or backing off the container, the bearing adjustment is made. The bearings should be set with the same adjustment as shim adjusted bearings (0.005 to 0.008-inch end play). To get an accurate check on the end play in the bearings, an indicator should be used.

b. Full-Floating Rear Axle.

(1) To adjust the bearings in a truck rear wheel on a full-floating rear axle (detail B, fig. 56), relieve the tires of all load, but do not remove the wheels. On the full-floating rear axle, the two

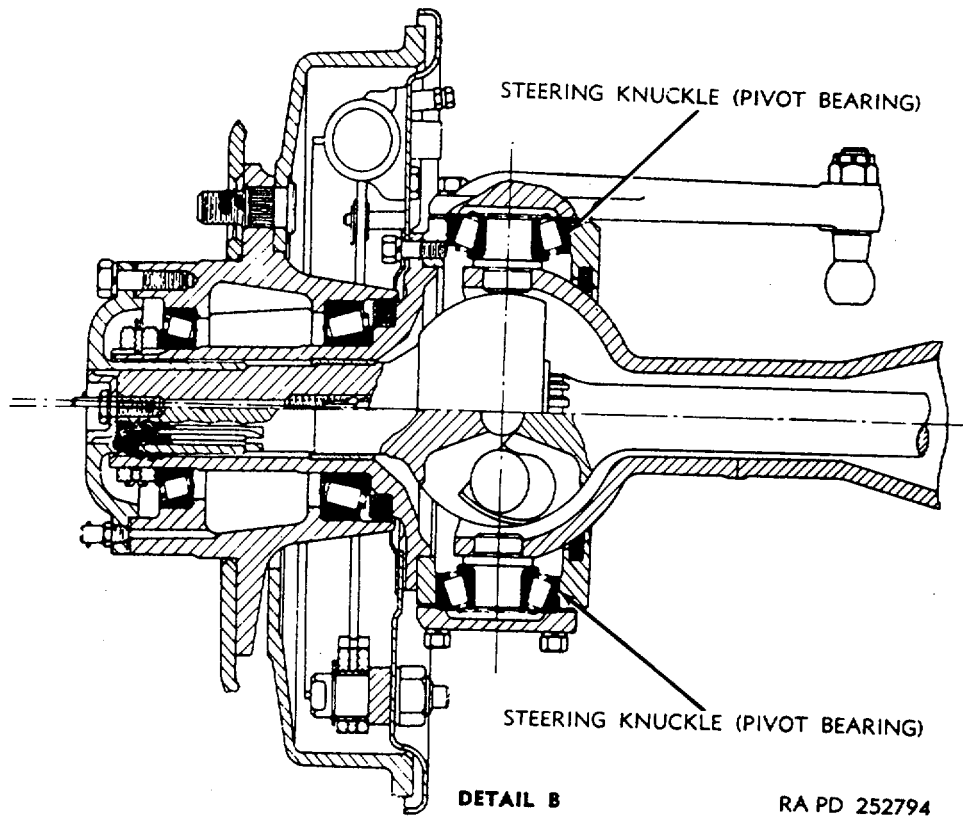
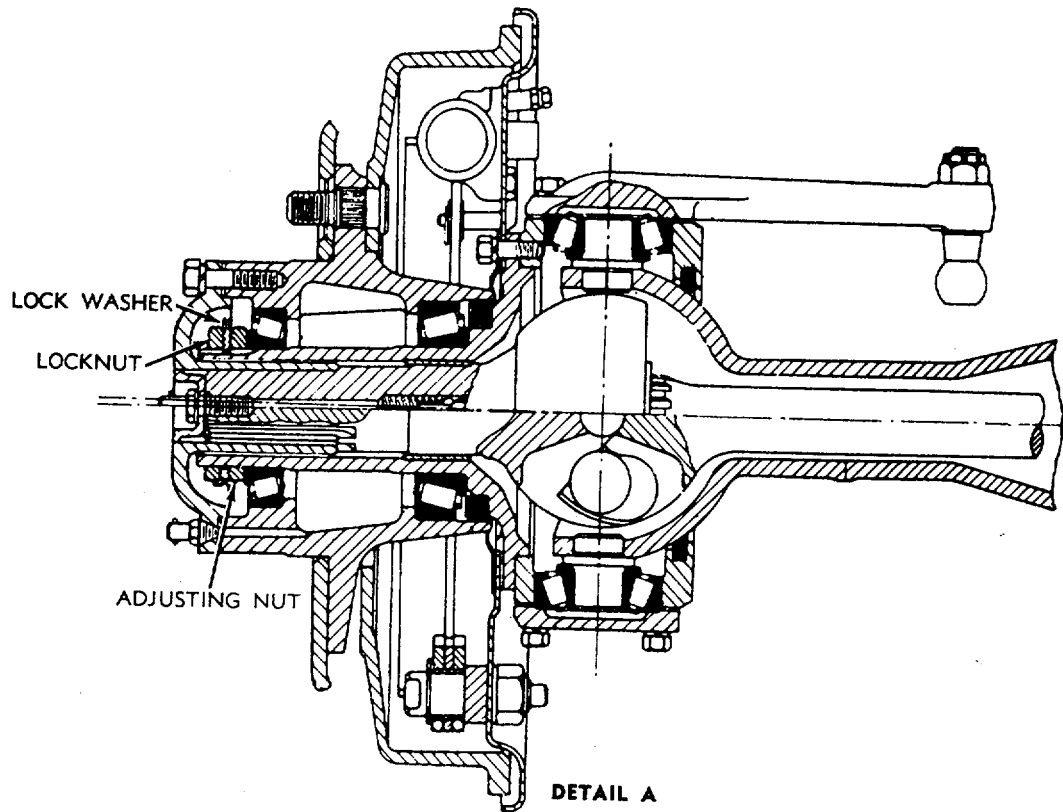

RA PD 252794

Figure 54. Front wheel drive adjustment.

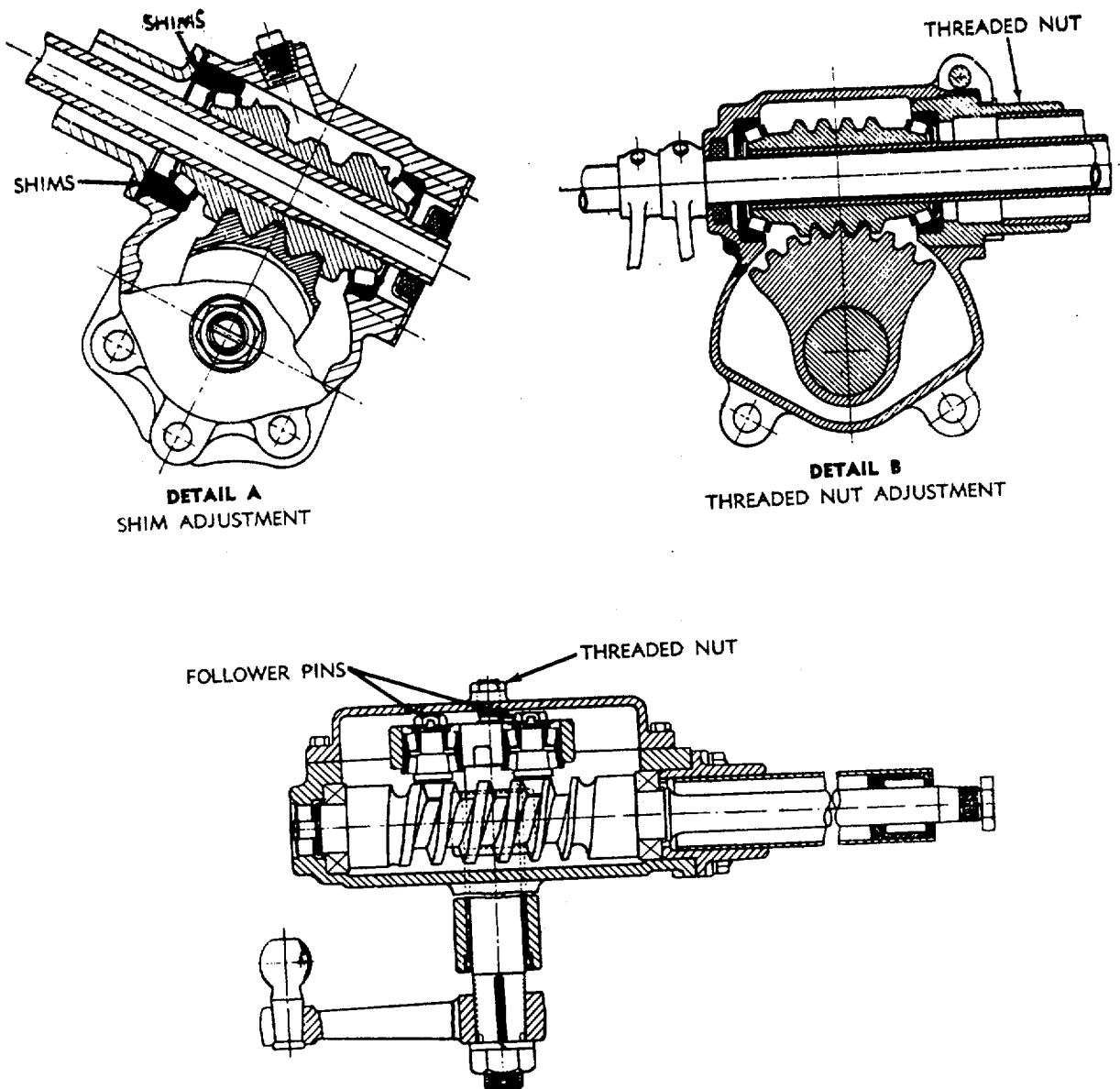

Figure 55. Steering gear adjustment.

bearings are mounted in the hub of the wheel similar to the front wheel application.

- (2) To adjust bearings, remove hub cap and drive shaft, then adjustment should be made by rotating the wheel in both directions while taking up on the adjustment nut. For front wheel drive bearing adjustment follow procedures outlined in paragraph 35b, c, and d.

40. Propeller Shaft Bearing Adjustment

There are two types of adjustments commonly used on propeller shaft installation, the locknut and lockwasher adjustment and the spacer adjustment as listed in a and b below.

a. *Locknut and Lockwasher Adjustment* (detail A, fig. 57). To adjust propeller shaft bearings, disconnect the propeller shaft and remove locknut and lockwasher. Take up adjusting nut until there is 0.001 to 0.003-inch end play. Install lockwasher and locknut and make certain

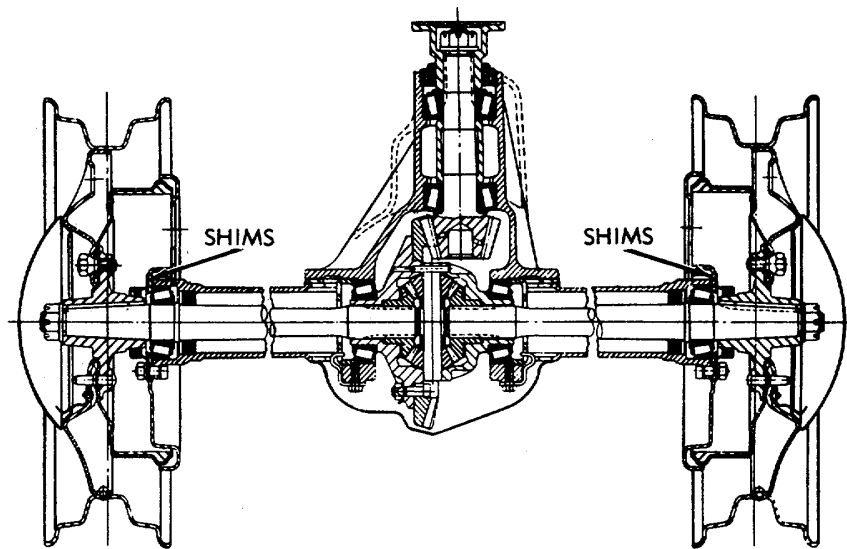

DETAIL A
FIXED-HUB TYPE, SINGLE BEARING

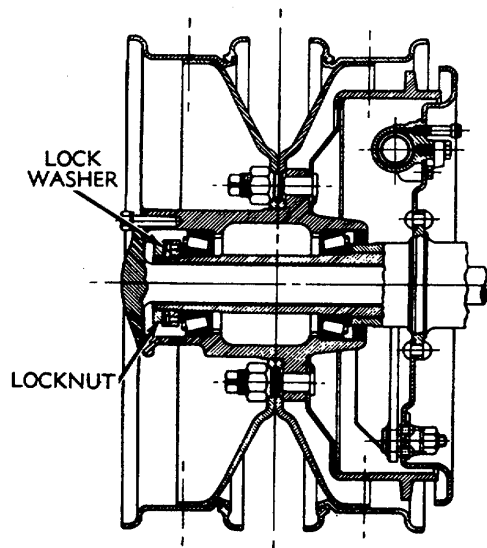

DETAIL B
FULL FLOATING REAR AXLE

RA PD 252796

Figure 56. Rear wheel bearing adjustment.

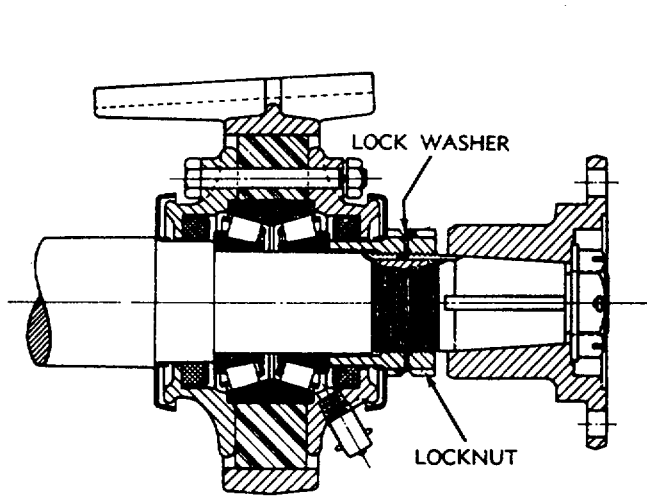

DETAIL A
LOCKNUT AND LOCK WASHER ADJUSTMENT

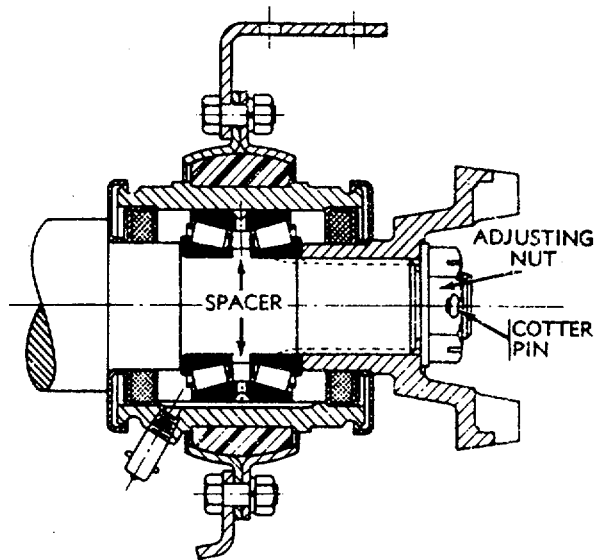

DETAIL B
SPACER ADJUSTMENT

RA PD 252797

Figure 57. Propeller shaft bearing adjustment.

that the locknut does not disturb bearing adjustment.

b. Spacer Adjustment (detail B, fig. 57). In this type mounting, the bearing adjustment is made by means of a selective spacer between the cones. The bearings should be adjusted to rotate freely without perceptible end play. Excess end play can be taken up by grinding the cone spacer to the proper length. Make certain that the faces of the spacer are parallel.

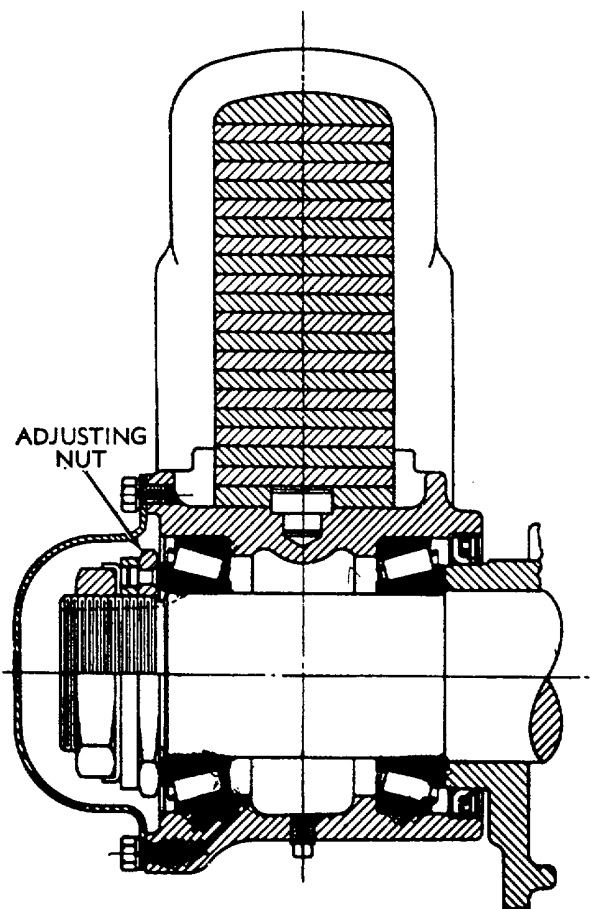

RA PD 252798

Figure 58. Spring seat bearing adjustment.

41. Spring Seat Bearing Adjustment

The adjustment of spring seats must be made with the rear axles disconnected from the springs. Check the adjustment of these bearings when the axles are being serviced. To adjust bearings, tighten the adjusting nut (fig. 58) until a slight bearing drag is noticed when the spring seat is oscillated. Bearing adjustment must not be confused with seal drag.

42. Pinion, Worm Cross-Shaft, and Differential Bearing Adjustment

a. Axle Carrier. The axle carrier must be removed from the axle housing to adjust pinion, worm cross-shaft, and differential bearings in a double reduction differential carrier mounting. In making pinion, cross-shaft, and differential bearing adjustments, care must be taken so that the pinion and ring gear are in the same relative

position as they were before adjustment was made.

b. Pinion (Overhung Mounting) (detail A, fig. 59). The pinion bearings on overhung mountings should be adjusted with 10 to 20 pound-inches torque. Where shims are used, proper adjustment can be made by selecting a new spacer of proper size or by grinding the existing spacer. Make certain that end faces of the spacer are parallel.

c. Pinion (Straddle Mounting) (detail B, fig. 59). In straddle pinion mountings, two bearings are mounted adjacent to each other in front of the pinion, and a straight roller or ball bearing is mounted back of it. The correct adjustment for all straddle mounted pinion bearings is within the range of 5 to 15 pound-inches torque. Where shims are used between the cones, sufficient shims must be provided to obtain proper bearing adjustment. When selective spacers are used, adjustment can be made by selecting a new spacer of proper size or by grinding the existing spacer. Make certain that end faces of the spacer are parallel.

d. Worm. Cross-Shaft (detail A, fig. 59). The cross-shaft bearings should be set up with 10 to 20 pound-inches torque. The conventional mounting uses shims. To obtain the proper gear setting, the same thickness of shims should be removed from each side.

e. Differential (details A and B, fig. 59). Differential bearings are set up with 25 to 35 pound-inches torque to insure a rigid mounting for the gears. In some instances, due to variation in stiffness of the pedestals or the case, this torque can be increased or decreased as needed to insure desired rigidity in gears. In some rear axles, the differential bearings are adjusted by shims or selective spacers between the cone and shoulder or cup and shoulder. Adjustment is made by changing shims or spacers to get the desired torque.

43. Transfer Case Bearing Adjustment

a. To adjust bearings in transfer cases, the unit must be removed from the chassis as all propeller shafts and take-off drives must be disconnected.

b. The bearings in all types of transfer cases should normally be adjusted with 0.003- to 0.005-inch end play (detail A, fig. 60), unless otherwise specified by the manufacturer of the equipment.

Note This also applies to power take-off units used in conjunction with transfer cases.

Transfer cases having a separate declutching unit for the front axle should have the bearings adjusted with no end play but with free turning.

c. Checking the adjustment of the various shafts is accomplished by placing an indicator (detail B, fig. 60) against the end of the shaft, then oscillating the shaft and at the same time applying force to the end of the shaft, first in one direction then the other, and noting the indicator reading.

d. The adjustment can also be accomplished by removing shims until a slight binding is noted in the assembly, after which a shim is added, if necessary, to provide the recommended end play.

44. Auxiliary Transmission Bearing Adjustment

a. Auxiliary transmissions (fig. 61) are adjusted by disengaging the drive shaft at the rear of the transmission. It is not necessary to disengage the drive shaft at the front end, since this will have free rotation when the clutch is thrown out with the transmission in neutral.

b. Adjust the front main shaft which is equipped with two bearings. This adjustment should be taken up so that there is 5 to 10 pound-inches torque ON the bearings.

c. The rear two-row bearing on the main shaft should be set with 0.001- to 0.003-inch end play. Shims are added or removed to get the required adjustment.

d. The countershaft bearings should be set with 0.003- to 0.005-inch end play. Shims are added or removed to get the required adjustment.

45. Fixtures For Checking Bearing Adjustment

a. General. Fixtures and methods for checking the end play torque or tension on bearings are outlined in *b* through *e* below. Other fixtures and methods are available, but the ones shown are simple and inexpensive and are adaptable to the particular application for which they are needed. The use of these fixtures or methods will eliminate guesswork on the part of maintenance personnel and insure proper adjustment and operation of the bearings.

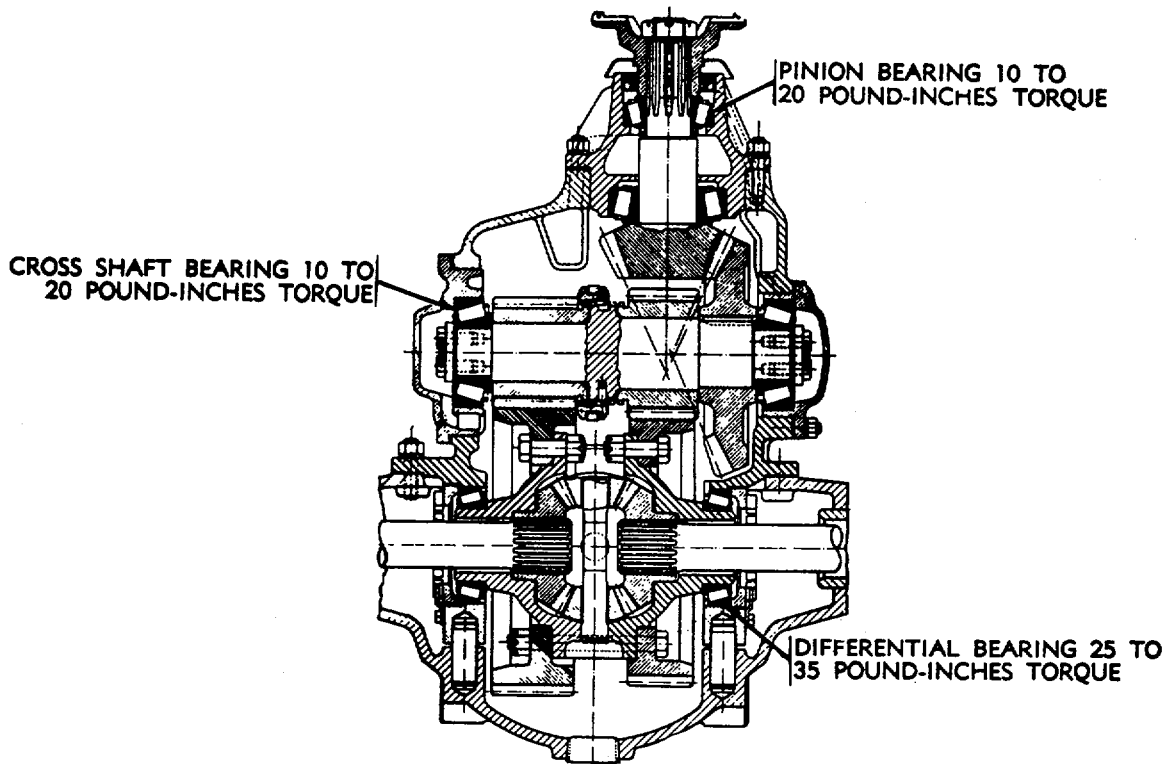

DETAIL A
OVERHUNG MOUNTING DOUBLE
REDUCTION CARRIER

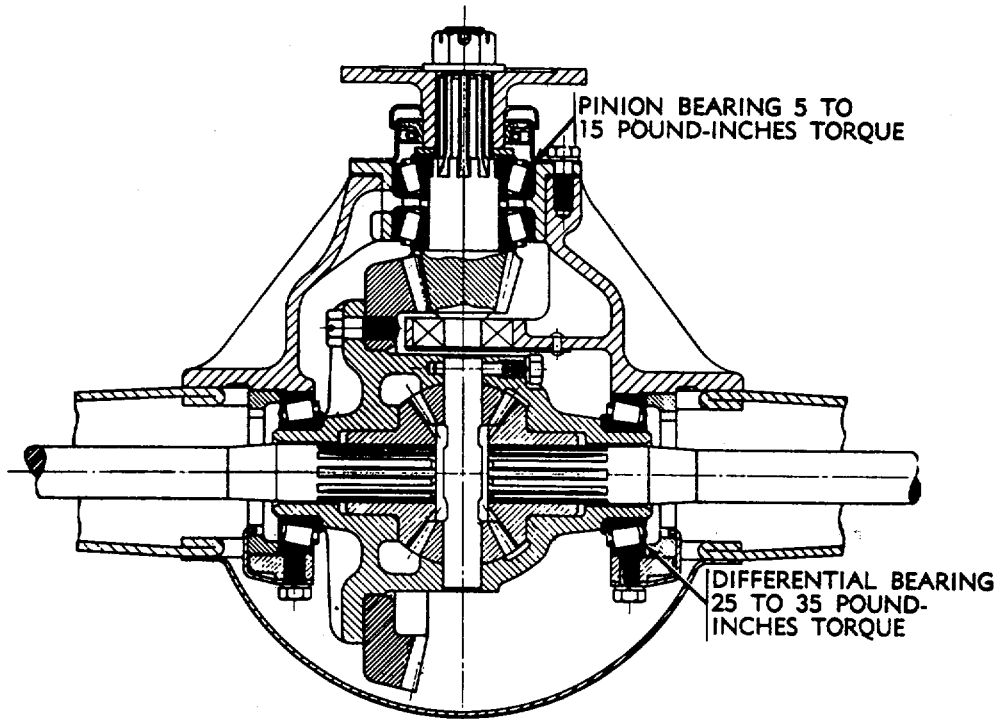

DETAIL B
STRADDLE MOUNTING DOUBLE REDUCTION CARRIER

RA PD 252799A

Figure 59. Pinion, cross-shaft, and differential bearing adjustment.

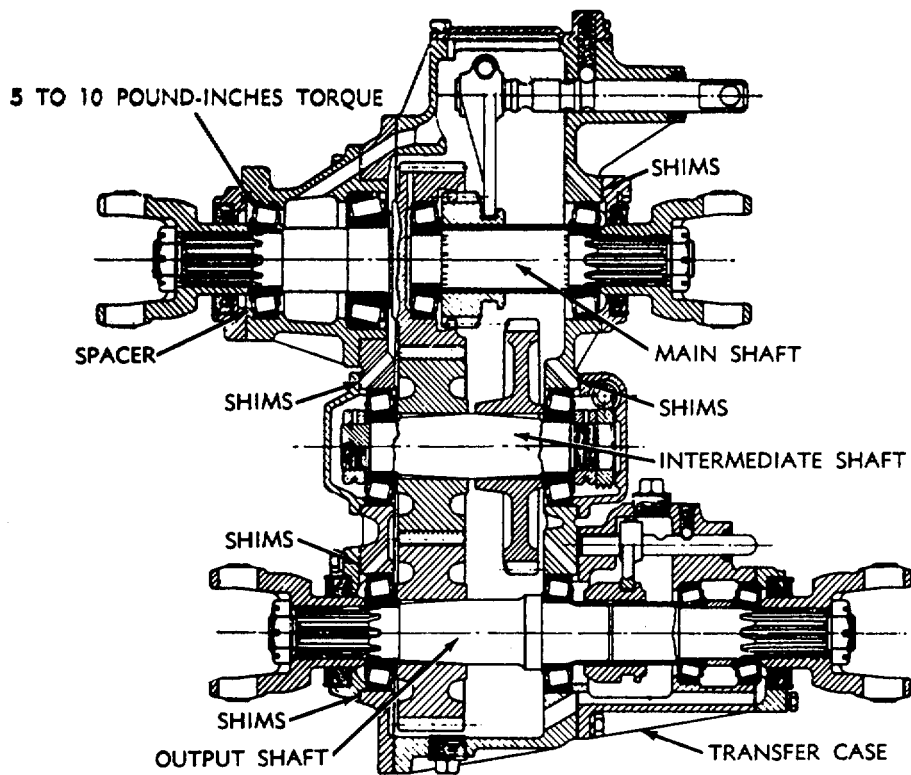

DETAIL A
 END PLAY ADJUSTMENT 0.003- TO 0.005-INCH (OR AS SPECIFIED)

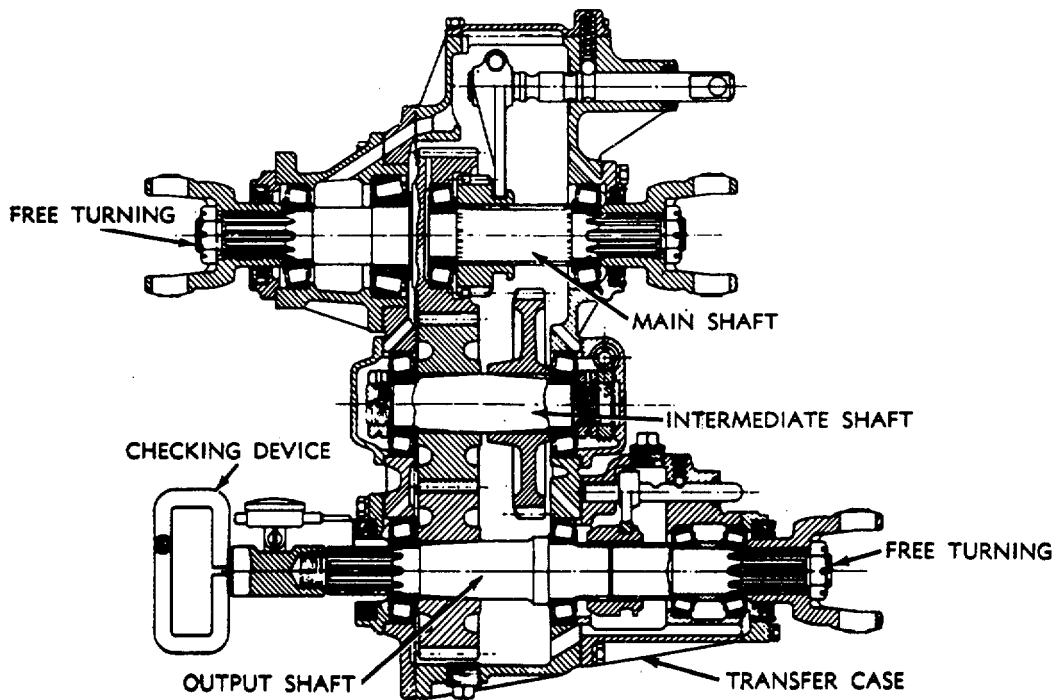

DETAIL B
 END PLAY CHECKED WITH INDICATOR

RA PD 252800A

Figure 60. Main, intermediate, and output shaft bearing adjustment.

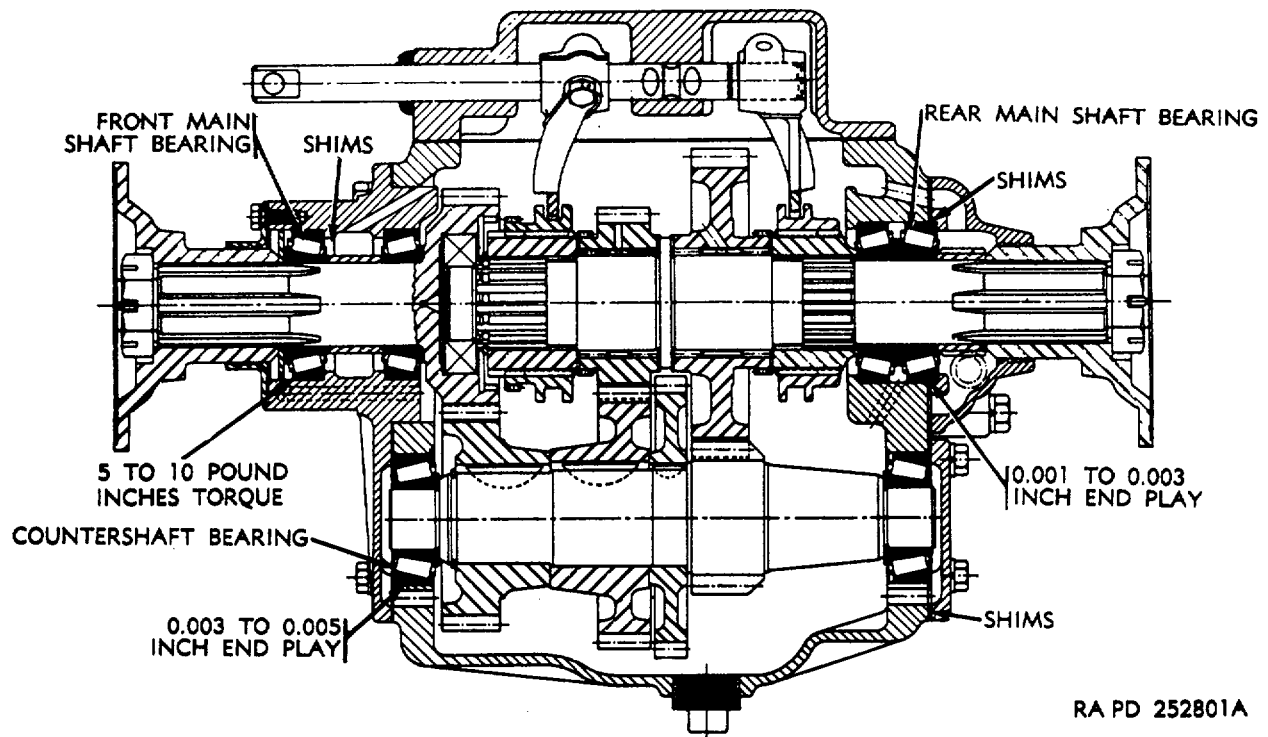

RA PD 252801A

Figure 61. Auxiliary transmission bearing adjustment.

b. Indicator End Play Device.

- (1) The fixture shown in detail A, figure 62, is a simple device for checking the lateral end play of a bearing in smaller cup adjusted applications. It consists of a handle with an indicator mounted on it. The handle can be screwed or clamped onto the shaft, or changed otherwise to fit the particular design for which it is used.
- (2) The fixture shown in detail B, figure 62 is more suitable for heavy shafts where it is more difficult to move heavier parts. It is important that the bearing be rotated when checking end play, in order to assure the proper seating of the rollers against the rib. This establishes a correct end play reading.

c. Torque Device. The torque devices shown S4 in details A and B, figure 63 illustrate the use of a 1-

pound weight on an arm which gives a simple, but quick and accurate check on bearing torque. The two designs shown with examples are the pin-type lever arm and the hook-type lever arm.

d. Spring Scale. A simple but accurate method of measuring torque or tension on the bearing is by means of a cord wrapped around the gear and a spring scale (detail A, fig. 64). Pound-inches torque is equal to the gear radius in inches multiplied by the pull in pounds at the end of the cord. Detail B, figure 64, shows the use of a torque bar and spring scale on a pinion shaft drive flange.

e. Torque Wrench. Standard torque indicating wrenches can be used for measuring bearing torque. The type of torque wrench shown in figure 65 is the simplest and most accurate method of checking bearing torque.

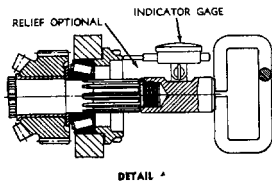

THIS TYPE OF FIXTURE IS USED FOR CHECKING THE LATERAL END PLAY OF A BEARING IN SMALLER CUP ADJUSTED APPLICATIONS. BY SCREWING THE CHECKING FIXTURE TO THE END OF THE SHAFT THIS CAN BE MOVED ENDWISE AND THE MOVEMENT READ ON THE INDICATOR.

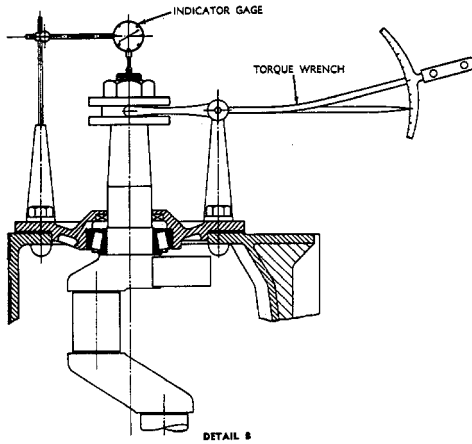

THIS TYPE OF FIXTURE IS MORE SUITED TO HEAVY SHAFTS WHERE IT IS MORE DIFFICULT TO MOVE HEAVIER PARTS.

ATTACH INDICATOR AND TORQUE WRENCH TO CASE OR FRAME AND GROOVED COLLAR TO SHAFT AS SHOWN.

THEN WITH SHAFT ROTATING SLOWLY APPLY ENOUGH PRESSURE THROUGH WRENCH TO ASSURE PROPER SEATING OF BEARINGS.

WHEN INDICATOR READING IS CONSTANT, SHOWING BEARING IS SEATED, SET INDICATOR AT ZERO AND THEN REVERSE' DIRECTION OF PRESSURE ON WRENCH, APPLYING SAME AMOUNT OF PRESSURE AS HAD BEEN APPLIED BEFORE.

WHEN AMOUNT OF PRESSURE REQUIRED TO SEAT BEARINGS IS ONCE SET, IT CAN BE USED AS STANDARD ON FIXTURE UNITS OF SAME OR APPROXIMATELY SAME SIZE MACHINE.

RA PD 252802

RA PD 252802

DETAIL B

Figure 62. Fixtures for checking bearing adjustments.

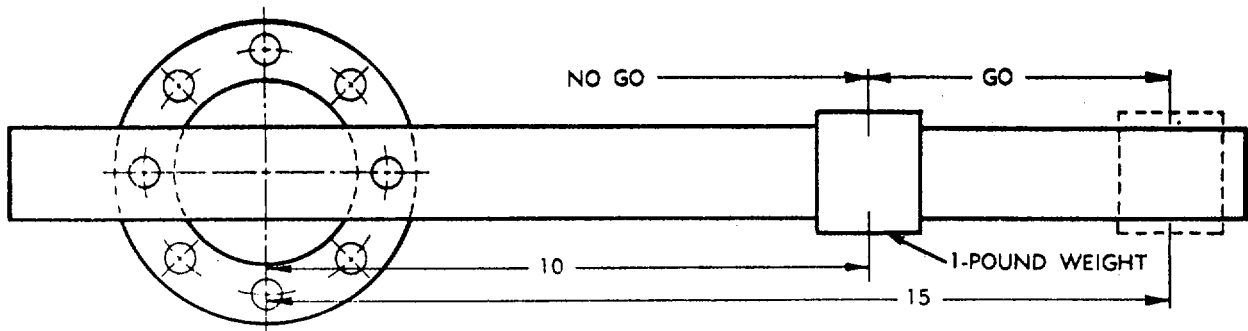

DETAIL A
PIN TYPE LEVER ARM

EXAMPLE

DESIRED PRELOAD-10 TO 15 POUND-INCHES FOR CORRECT TENSION ON BEARINGS. WEIGHT AT 10 WILL NOT TURN BEARINGS. AT 15 IT WILL TURN BEARINGS SO TENSION IS BETWEEN THE LIMITS OF 10 TO 15 POUND-INCHES

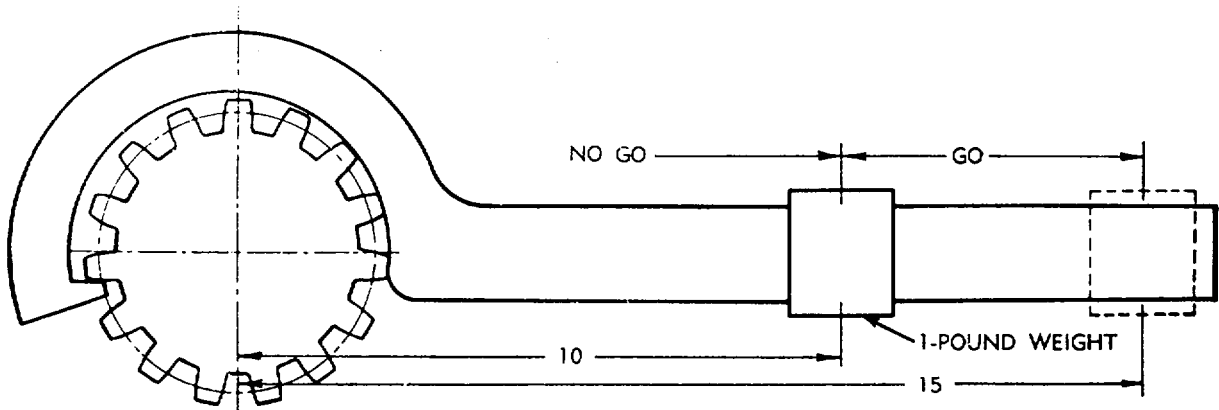

DETAIL B
HOOK TYPE LEVER ARM

EXAMPLE

1 POUND AT 10 MARK ON ARM = POUND-INCHES
1 POUND AT 15 MARK ON ARM = POUND-INCHES

NOTE: ALL DIMENSIONS SHOWN ARE IN INCHES

RA PD 252878A

Figure 63. Pin and hook type fixtures for checking torque on bearings.

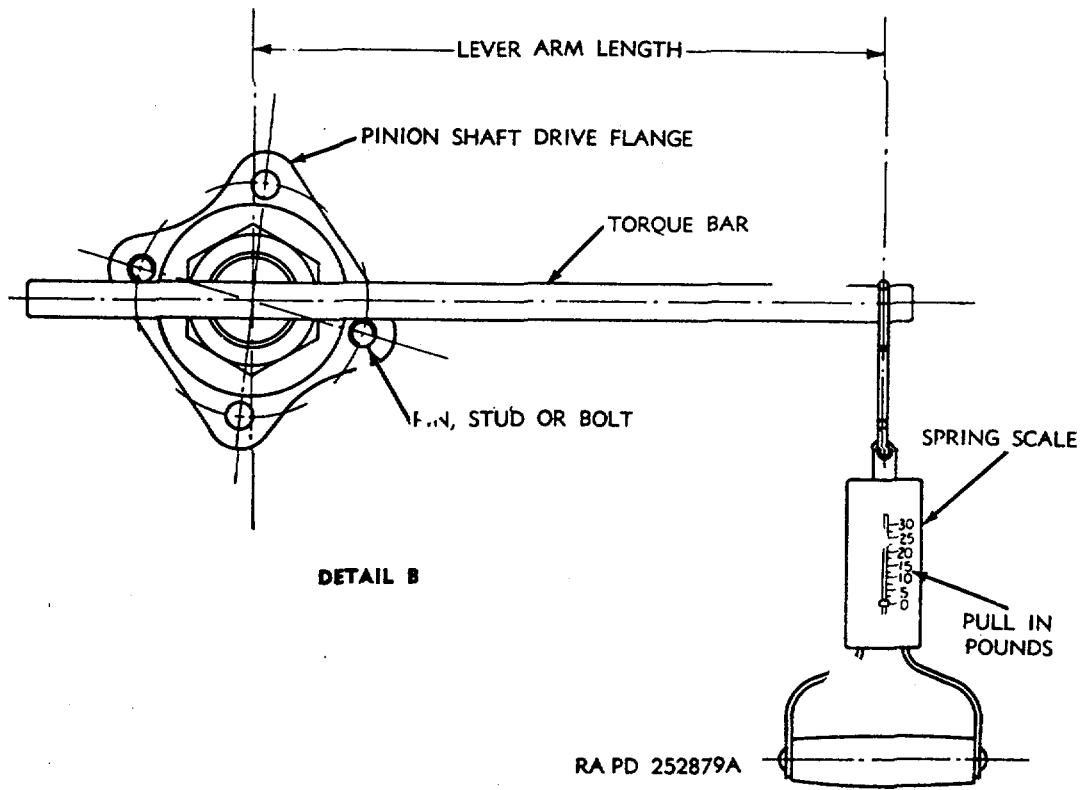
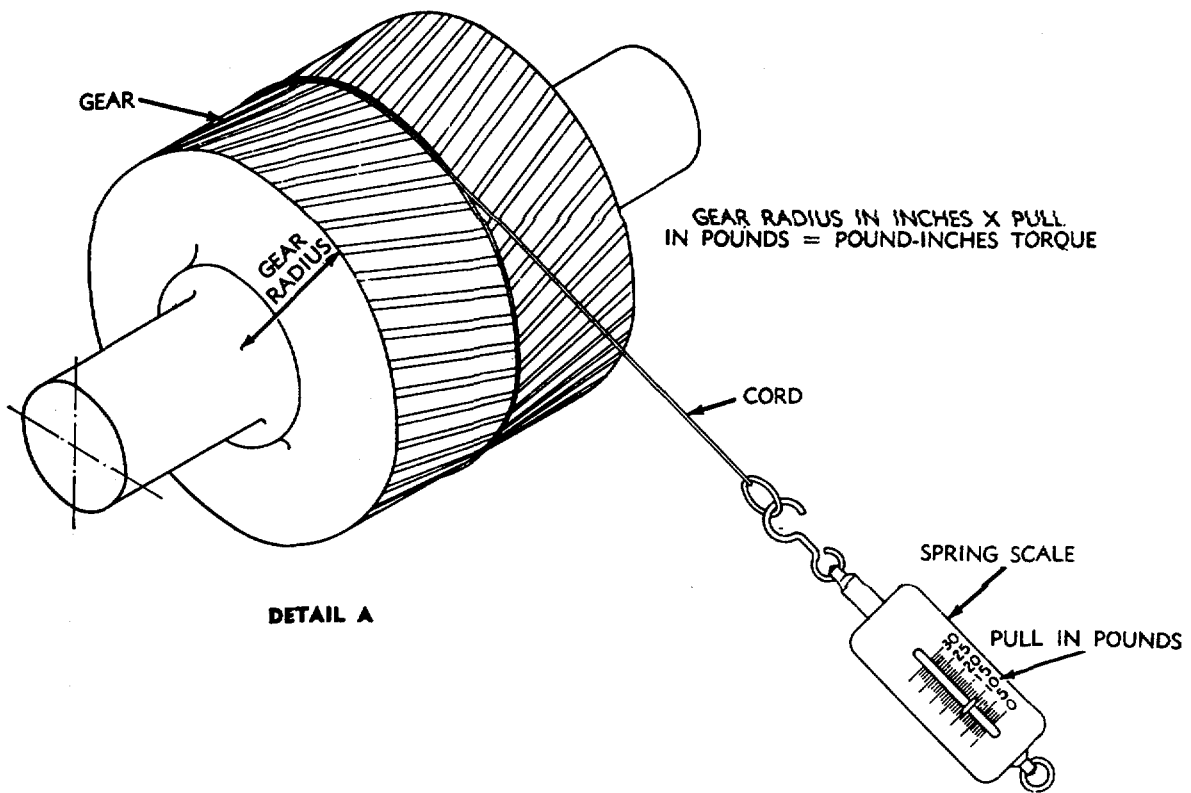

RA PD 252879A

Figure 64. Spring scale fixtures for checking torque on bearings.

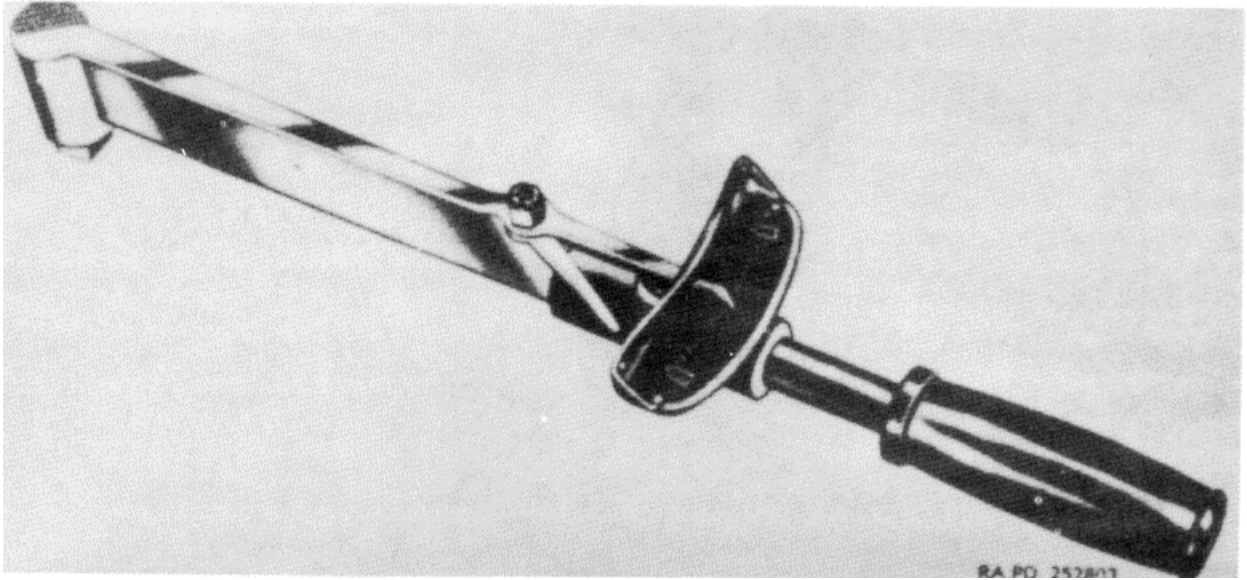

Figure 65. Standard torque indicating wrench.

AGO 2797A

68

Section VIII

LUBRICATION OF BEARINGS

46. General

a. Improper lubrication is the main cause of bearing failure. No bearing can perform at its maximum efficiency or give its maximum hour of service, unless the correct lubricant is applied in the proper amounts and at the proper time.

b. Antifriction bearings are made with tight seals. Forcing lubricants into them with a lubrication gun may burst the seals. The bearing will then leak until the seals are repaired. Excessive gun lubrication may also cause overloading the bearing by completely filling or clogging the bearing space. Balls or rollers will then have to force their way through the lubricant, creating lubrication friction, overloading, and even failure.

c. An adequately packed ball or roller bearing should be about one third full in the bearing space, leaving the sealing space, which is not in contact with the running balls or rollers, as full as it should be. Before lubricating the bearing, remove the drain plug, pack the lubricant in until it comes out at the drain plug, and then run the bearing for about 5 minutes. Replace the drain plug after the bearing has had a chance to force out the excess lubricant.

d. Tight seals and proper packing enable some machines which have antifriction bearings to be operated approximately 4 to 6 months, without bearing relubrication. Improper packing, on the other hand, may make daily bearing relubrication necessary.

47. Correct Lubrication

a. Correct antifriction bearing lubrication serves several definite functions as prescribed in (1) through (4) below.

- (1) Protects the precision ground and polished surfaces from rust and corrosion.
- (2) Minimizes friction resulting from the contact and slippage between moving parts and their raceways.
- (3) Aids in dissipating excessive heat.

- (4) Seals out water, scale, acid, abrasive, and corrosive matter which might enter and damage the bearing.

b. Although functions listed in (1)a through (4) above may be considered basic, it is nevertheless necessary to consider each bearing application and select the proper lubricant to meet existing conditions to the best advantage. Obviously, it is difficult to formulate definite rules for the selection of lubricants because of the many different conditions encountered.

c. Free-flowing oils are frequently used in various kinds of antifriction bearing lubrication under certain conditions, especially in the case of miniature ball bearings. Under other circumstances, grease lubrication is recommended. Grease, which is actually a mixture of oil and soap, forms a plastic film on the bearing and in this manner reduces friction, wear, power consumption, and leakage. Grease is preferable to oil in the types of service listed in (1) through (4) below.

- (1) Areas where the application of a lubricant is infrequent or hazardous owing to the number of bearings and their inaccessibility.
- (2) Mechanical designs in which the bearing is exposed to the entrance of grit or water. Correctly selected grease acts as a seal and thereby helps to prevent wear.
- (3) Mechanical designs that would result in excessive oil leakage (often brought about by high operating temperatures) and high oil consumption.
- (4) Low operating speeds and heavy pressure conditions which prevent the ready formation and continued maintenance of adequate separating films.

48. Choice of Lubricant

a. Choice of the correct lubricant for different types of ball or roller bearings varies due to the wide range of speeds and loads involved. When these conditions are adequately met, the antifriction bearing will require only a minimum amount of attention.

b. Lubricants selected for antifriction bearings should have the properties as outlined in (1) through (5) below.

- (1) High chemical stability to prevent the formation of deposits or acid materials harmful to bearing surfaces.
- (2) Good water-separating characteristics, particularly when bearings are lubricated from a water circulating system.
- (3) Correct viscosity for operating speeds and temperatures.
- (4) Good antiwear or film strength characteristics, especially where heavy or shock loads are involved.
- (5) Adequate adhesive qualities for protection during idleness.

c. Factors which influence the choice of the proper lubricant include agitation, length of service, operating temperatures, water and moisture content, and excessive throw and leakage. Three basic types of greases for antifriction bearings that are designed to solve these specific problems are lime base, soda base, and soap base.

49. Cleanliness of Lubricant

a. Cleanliness of the lubricant is of vital importance. Dirt, dust, or any other contamination shortens the life of a bearing. Dirt particles in the lubricant, for example, may get in between the moving elements and races and may cause pitting on the precision finishes. Also, clogged passages may prevent the lubricant from reaching the bearing.

b. Be sure the lubricant used for antifriction bearings has been filtered. Unfiltered lubricants often contain foreign matter harmful to bearing surfaces.

c. In order to insure operation free from damage by the lubricant, observe the following rules.:

- (1) Use only clean fresh lubricants when refilling the lubricant reservoir, especially after dismounting and cleaning the bearing.
- (2) With grease-lubricated bearings, the grease must be completely removed, the bearings and housings cleaned thoroughly, and fresh grease added at frequent intervals.
- (3) With oil-lubricated bearings, the oil must be drained, the bearing and housing cleaned or flushed with flushing oil, and fresh oil added at frequent intervals.

- (4) Avoid the use of graphitic lubricants which form large sludge or gum deposits.
- (5) Keep lubricants in waterproof and dustproof containers.
- (6) All lubricants used for bearings should be filtered.

50. Storage and Segregation of Lubricants

a. Proper storage and segregation of bearing lubricants (more than one type is generally required) is essential to good maintenance operations.

b. To avoid getting the lubricant designated for one type of bearing into another type, use only one type of lubricant in a gun and have the gun carefully marked.

c. Only properly trained personnel should be permitted to handle the lubricating guns.

d. Store lubricants in clean containers and keep containers covered at all times.

51. Lubrication Instructions

a. *General.*

- (1) Lubricate bearings in accordance with the detailed instructions contained in the pertinent technical manual or lubrication orders covering the equipment in which the bearing is used. These instructions specify the frequency of use, the quantity, and the type of grease or oil to be used.
- (2) Follow these instructions carefully. Use only the lubricant that the instructions prescribe.

Note. Follow instructions prescribed in *b* through *h* below only when specific instructions are not available.

- (3) Do not use grease where oil is specified.

b. *Lubrication Materials.*

Note. If larger or smaller quantities than indicated are required, refer to pertinent supply manuals for applicable stock numbers.

- (1) *Lubricating oil, compounded (9150243,-3198) (55-gal. drum) (MIL-L-15019). Used for reciprocating steam*

bead guides (subject to wet conditions), wick feed, sight feed oilers, and dry pans.

(2) *Lubricating oil, general purpose (9150 -268-4490) (1-qt. can) (MIL-L-7870)*. This is a general purpose low temperature lubricating oil, having low evaporation and rust protective properties.

(3) *Lubricating oil, instrument (9150-223 -4129) (1-qt. can) (MIL-L-6085)*. This is a synthetic base oil used for aircraft instruments, electronic equipment, and where a low evaporation oil is required for low and high temperatures.

(4) *Lubricating oil, railway (9150-257-5447) (55-gal. drum) (VV-0-471)*. Used as an all season lubrication for journal bearings of railway cars, standard electric locomotives, and army railway gun carriages.

(5) *Grease, aircraft (9150-223-4008) (1lb. can) (MIL-L-3545)*. Used for antifriction bearings operating at high speeds and high temperatures or where retention and water resistance is desired.

(6) *Grease, aircraft (9150-257-5361) (1lb. can) (MIL-L-7711)*. Used for antifriction bearings, gear boxes, and plain bearings where both reasonably low temperature operations and high temperature stability may be required.

(7) *Grease, graphite (9150-223-4001) (1lb. can) (MIL-G-7187)*. Used for heavily loaded intermittent applications, such as starter gears on slow moving plain bearings and sliding surfaces where graphite will prevent seizure in event of inadequate lubrication. Not recommended for general use or ball bearings.

(8) *-Grease, aircraft and instrument (9150 -261-8298) (1-lb. can) (MIL-G-8278)*. Used for aircraft and instruments. Permits operation of equipment at -65° F., and will lubricate bearings continuously at temperatures as high as 250° F., and for short periods at temperatures as high as 300° F.

(9) *Grease, automotive (9150-257-5363) (85.-lb. pail) (VV-G-632)*. Used for water pump bearings and other paints on equipment as specified.

(10) *Grease, automotive and artillery (9150 -249-0912) (25-lb. pail) (MIL-G-10924)*. Used for lubrication of automotive and artillery materiel under all conditions and services where ambient temperatures range from -65° to +125° F.

(11) *Grease, ball and roller bearing (9150-249-0908) (35-lb pail) (MIL-G-18709)*. Used for rotating, sliding, or roller bearing surfaces at constant or intermittent speeds.

(12) *Grease, silicone insulated electric motor (9150-257-5358) (8-oz. tube) MIL-L-15719A)*. This is a high temperature grease used for the lubrication of ball and roller bearings only, primarily for lubrication of class H insulated (silicone) electric motors, with heat stabilized ball bearings. Not to be applied to bearings in which main action involves sliding of metal on metal as in journal bearings, spiral gears, gear trains, and similar application. Normal temperature range is from 0° to 300° F.

c. Open Bearings (Except Instrument). Except for instrument bearings, all open bearings including separate cones and those having shields or seals on one side only, will be pressure lubricated with automotive and artillery grease (b (10) above). All exterior surfaces, including all surfaces of separate cups, will be coated lightly with this grease for protection against rust or corrosion.

d. Instrument Bearings (Except Open-Type). Instrument bearings, except instrument and precision open-type oil lubricated bearings, will be pressure lubricated with automotive and artillery grease. Cover the exterior surfaces with a light coating of this grease for protection against rust or corrosion.

e. Instrument and Precision Open-Type Bearings. For preservation and lubrication of instrument and precision open-type oil lubricated bearings, use instrument lubricating oil (b(3) above).



Figure 66. Hand lubrication of bearing. '

f. Shielded and Sealed Bearings. Bearings which are shielded and sealed on both sides will be pressure lubricated with aircraft and instrument grease to replace the contained grease as completely as possible. Apply a light coating of aircraft and instrument grease to all exterior surfaces.

Note. A bearing being lubricated by hand is shown in figure 66.

g. Air-Driven Gyro Instrument and Automatic Pilot Rotor Bearings.

- (1) *General.* The lubricants used in gyro rotor bearings serve primarily to protect the surfaces from corrosion and secondarily as a lubricant. Materials used should perform these functions with a minimum evaporation rate at high temperatures or in long term storage periods and at the same time be sufficiently fluid to permit satisfactory rotor speed at low temperatures. Methods of lubricating rotor bearings and rotor pivots are

outlined in (2) through (5) below.

Note. A small amount of aircraft and instrument grease used in conjunction with general purpose lubricating oil (b(2) above) will improve these qualities. However, it is necessary to control the amounts of oil and grease carefully to obtain the best performance under all operating conditions.

- (2) *Sperry and Ternstedt five-ball bearings.*
 - (a) Thoroughly clean and dry the bearings in accordance with instructions contained in section IV.
 - (b) Immerse the bearing assembly for 3 minutes in general purpose lubricating oil maintained at a temperature of 225° F.
 - (c) Place bearing on clean, dry absorbent paper and heat in oven for 1 hour at 225° F. Space bearings on blotting paper at least 1 inch between centers, retainer side down.
 - (d) Remove bearings from oven and blot excess oil from top of bearing with clean blotting paper. Place bearings, retainer side down, on wire screen and cover tightly to prevent contamination while bearing cools to room temperature.
- (3) *Rotor shaft pivot for Sperry and Ternstedt five-ball bearings.*
 - (a) Thoroughly clean and dry rotor pivots in accordance with instructions contained in section IV.
 - (b) Dip each end of rotor shaft in special container (detail B, fig. 67) filled with aircraft and instrument grease at room temperature and withdraw so that entire surface of pivot is covered with an even film of grease.

Note. If grease film appears to be uneven, or extends beyond the pivot cone, clean and redip the pivot.

- (c) Immediately assemble gyro assembly, being careful not to touch the greased pivots to anything except bearing balls.
- (4) *Jack and Heintz eight-ball bearings.*
 - (a) Prepare bearings as described in (2) (a), (c), and (d) above.

- (b) Dip lubricating cone (detail A, fig. 67) in aircraft and instrument grease (b(8) above) at room temperature and withdraw so that cone is evenly coated with grease. Touch cone to bearing assembly so that each ball is touched, rotate cone 90 degrees on balls and remove.
- (5) *Jack and Heintz rotor shaft pivot.*
 - (a) Thoroughly clean and dry rotor shaft pivots.
 - (b) conical surfaces of pivot with clean chamois skin soaked in general purpose lubricating oil (b (2) above.) for corrosion protection.
- (6) *Miscellaneous.*
 - (a) Oil retaining pads made of material other than metal must not be used with rotor bearings when lubricated as prescribed herein. Install metal disk oil retainers (lubricators) and saturate each disk with 1 drop of general purpose lubricating oil.
 - (b) All gyro instruments having rotor bearings lubricated as prescribed herein N ill be identified with the letter "G" approximately one-half inch high painted or stenciled in yellow the top of the instrument case.
 - (c) Instruments lubricated as prescribed herein or identified by the manufacturer as having aircraft and instrument grease in the rotor bearings will not be given a rotor coast test as a criterion of rotor setup or instrument serviceability.
- (7) *Tests.*
 - (a) Perform a starting test as follows: Start the rotor twice on a pressure differential of 4 inches of mercury. Allow the rotor to stop and apply gradually increasing differential pressure. The rotor will start and continue to run on a pressure not to exceed 1 inch of mercury.
 - (b) Rotor assemblies will be given an r.p.m. test prior to assembly, in accordance with the tolerances outlined in 1 and 2 below, with a differential pressure of 4 inches of mercury across the test fixture.
 1. Directional gyro indicators and directional gyro control units, 7,500 to 13,500 r.p.m.

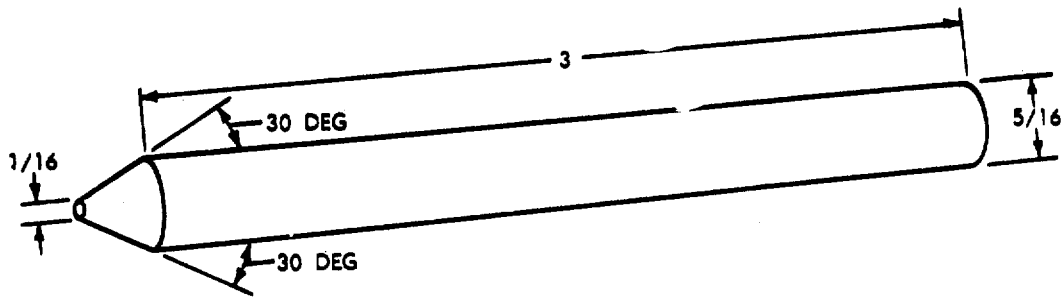

DETAIL A
CONE-GREASE APPLICATOR FOR EIGHT-BALL BEARINGS

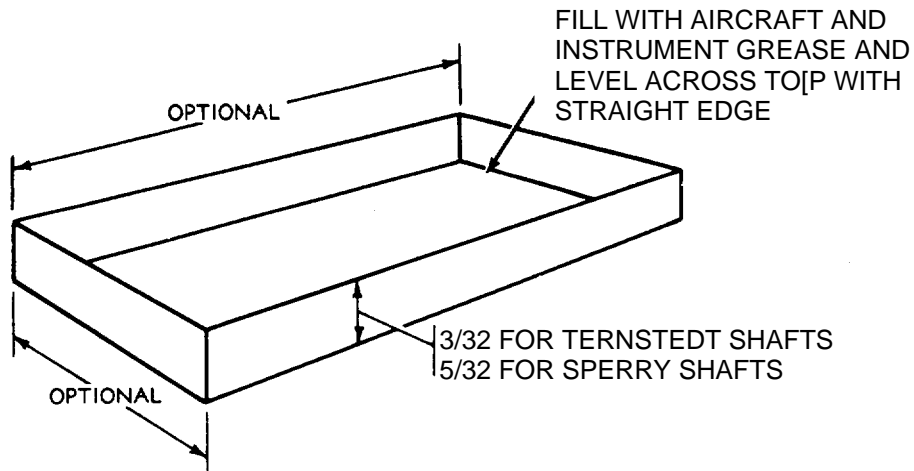

DETAIL B
GREASE CONTAINER FOR ROTOR SHAFT LUBRICATION

NOTES: 1-ALL DIMENSIONS SHOWN ARE IN INCHES
2-DETAIL A AND B ARE CONSTRUCTED OF
BRASS OR ALUMINUM ALLOY

RA PD 252764

Figure 67. Rotor shaft grease container and cone-grease applicator for eight-ball bearings.

2. Gyro horizon indicators and bank and climb control. units, 15,000 to 20,000 r.p.m.
- h. *Antiaircraft Artillery Wheel Bearings.*
 - (1) Remove wheels in accordance with the pertinent technical manual for antiaircraft artillery materiel.
 - (2) Clean all the old grease from wheel bearing, drum, armature plate, castle nut, axle spindle washer, hub cap, and hub and axle spindle with mineral spirits, paint thinner or dry-cleaning solvent.

Caution: Do not allow any solvent to get on the brake lining or magnet. It is extremely important that all

components, particularly bearings, be cleaned thoroughly to remove all traces of previously used lubricants, prior to lubricating with automotive and artillery grease.

- (3) Wipe and dry the solvent off the wheel bearings. Do not use compressed air to dry bearings, as it is likely to damage the bearing and also cause rusting should the compressed air contain moisture.
- (4) In packing bearings, apply automotive and artillery grease carefully between the rollers by kneading the grease thoroughly into all spaces in the bear

ing with the palm of hand or with the aid of a mechanical packer.

Caution: Exercise extreme care to see that dirt, grit, lint, or other contaminants are not applied into the bearings; assemble the bearings and replace the wheel immediately. Check grease retainers for proper condition and replace, if necessary.

- (5) The method of packing the hub cap with grease and utilizing it as a grease cup is not to be used under any circumstances. This procedure may

heat up the grease, rupture the grease seal, and result in grease-soaked brake linings and shorting of the electrical circuits, rendering the brake inoperative. The lubricant, when properly kneaded into all spaces in the bearing, is sufficient to provide lubrication until the next service period.

- (6) To prevent rusting, coat the spindle and inside of the hub and hub cap with automotive and artillery grease to a maximum thickness of one-sixteenth inch.

AGO 2737A

Section IX

AUXILIARY EQUIPMENT

52. Closure of Seals

a. Inspect the closure or seal used at the shaft opening each time a bearing is serviced or replaced. Seals are designed to serve two purposes mainly, to keep the lubricant in and to keep dirt out. They must be replaced with new seals when inspection indicates they are failing to function properly.

b. There are many types of seals, each designed for a different kind of application. One of the most common is a simple felt ring. These rings can be replaced each time a machine is overhauled. They should be replaced more often if they show evidence of wear, scuffing, or of becoming brittle. The 1-piece stamped ring type seal is preferable to the split rim type. If the method of installation requires that a split rim washer be used, a single cut on the bearing should be made and care should be taken that the joint is closed properly and the washer assembled without distortion. Soak felt seals in oil prior to installing.

c. Flange-type seals are used where a more positive type of closure is desired. As the sealing element, they have leather, asbestos, composition, or other suitable material usually shaped to form a wiping lip. This lip is held against the shaft at a constant pressure by means of a spring and assembled in a steel stamping. There are many variations of this basic design, such as double seals, felt and leather, or felt and composition combinations.

d. The mounting of flange-type seals should be accomplished with special care, as they are easily damaged through mishandling. In most cases, the seal is mounted with the wiping lip toward the bearing, since the inside diameter of the seal is less than the shaft diameter, some difficulty may be experienced in starting the seal over the end of the shaft. Remove all sharp corners and burs over which the seal has to move.

e. A tapered or bullet shaped adapter, recessed to fit the shaft chamber, should be used to carry the seal over the shaft end.

f. If keyways or splines are present, extend the adapter into a thin-walled thimble. This will cover the

undercut section of the shaft and carry the seal to the smooth section.

g. The seal is then mounted in the housing in the same manner and with the same care as the bearing. Place a little oil or grease on the sealing element and lubricate the shaft to assist in mounting the seal.

h. Move the seal along the shaft with a twisting motion to overcome friction. Apply a thin coat of shellac to the outer surface of the steel stamping, this will assist in making the press fit more resistant to leakage.

53. Gaskets and Shims

a. Gaskets are used to prevent leakage between mating flat surfaces and also serve to adjust bearings. Gaskets become brittle with age and high temperature, and should be replaced each time they are exposed for bearing inspection.

b. Secure the gasket to one of the surfaces with a thin, even coat of shellac and allow to dry before the parts are fastened together.

c. Trim loose gasket material or frayed edges before assembly to prevent particles from getting into the bearing or into the lubricating system.

d. Examine shims, either metallic or fibrous, with each bearing inspection. Clean, replace, and/or repair shims which might affect bearing adjustment.

54. Lubrication Equipment

a. Lubrication is of prime importance in prolonging the life of bearings, therefore, take every precaution to insure perfect functioning of all lubricating equipment. All channels for the flow of oil or grease must be cleaned thoroughly, oiling equipment checked, and filters renewed or cleaned, when necessary.

b. With grease lubrication, check the vent holes as pressure gun greasing may cause over-lubrication.

c. Where felts or wicks are used in lubrication, clean or renew them as often as conditions require. Check any arrangement designed to maintain a constant oil level from time to time to make certain it is functioning properly.

AGO 2737A

55. Keys, Splines, and Grinding Reliefs

a. Clean keys, splines, and grinding reliefs thoroughly during every bearing inspection or replacement to remove all dirt that may become trapped in recesses and corners. If not thoroughly cleaned, the dirt and lubricant will mix and cause bearing damage.

b. Clean new machine parts having keys, splines, or grinding reliefs with a petroleum solvent to remove any grinding or lapping compound that may still be present.

c. Threaded sections must also be carefully cleaned before assembly. The nut used on the thread must be run up before assembling the bearing on the shaft. Therefore, if the threads have been improperly cut, or are damaged, they can be repaired without the necessity of removing the bearing from the shaft.

56. Snaprings

a. Snaprings are used to retain bearings and races which are not secured by a heavy press fit.

b. Clean the snapping groove to remove all possible dirt and to insure a firm seat for the ring.

The snapping must be ground or turned flat and must be free from burrs and sharp edges. It must also be shaped so that it fits the groove snugly, not being of such diameter that it bulges, or twisted so as to present an uneven surface to the bearing face.

c. The snapping ends must be of such design as to permit the ring to be removed easily from the application.

57. Washers and Cotter Pins

a. Washers should be flat and true to prevent distortion of the bearing when adjusting the assembly. They should be free from burrs to avoid scoring the shaft, or indenting the bearing by breaking off and circulating with the lubricant.

b. Clean cotter pin holes with a stiff piece of wire to remove old grease and dirt. Cotter pins must be replaced after having been used once because repeated bending will weaken the legs and allow them to break while in operation.

AGO 2737A

Section X

MARKING, STORAGE, AND SHIPMENT OF NEW BEARINGS

58. General

New bearings are carefully cleaned by the manufacturer and coated with a preservative prior to packaging. They are wrapped in greaseproof barrier-material to keep them clean. They are placed in a carton or other wrappings for further protection. New bearings should be kept in the original cartons or wrappings until ready for use (fig. 68).

59. Marking

a. General. Unit, intermediate, and exterior containers must be stenciled and/or marked in accordance with TM 9-1005. Where applicable, packages and shipping containers must be marked with appropriate bearing identification.

b. Precautionary Markings. In addition to marking as required in a above, the following marking will appear on one side of each unit and intermediate package:

PRESERVED-MIL-P-197
LUBRICATED WITH (SPEC. NO.)
OR

PRESERVED WITH (SPEC. NO.). CLEAN
AND LUBRICATE PRIOR TO USE

c. Embossing (Metal Cans). In addition to other required markings, all metal cans will be embossed on the lids with the stock number and date of packaging.

60. Storage of Bearings

a. In storage, the cartons should not be stacked too high in order to prevent damaging the lower packages by crushing. In all cases, the site selected for storage must be free from excessive heat and moisture, and away from dusty or corrosion-inducing atmospheres.

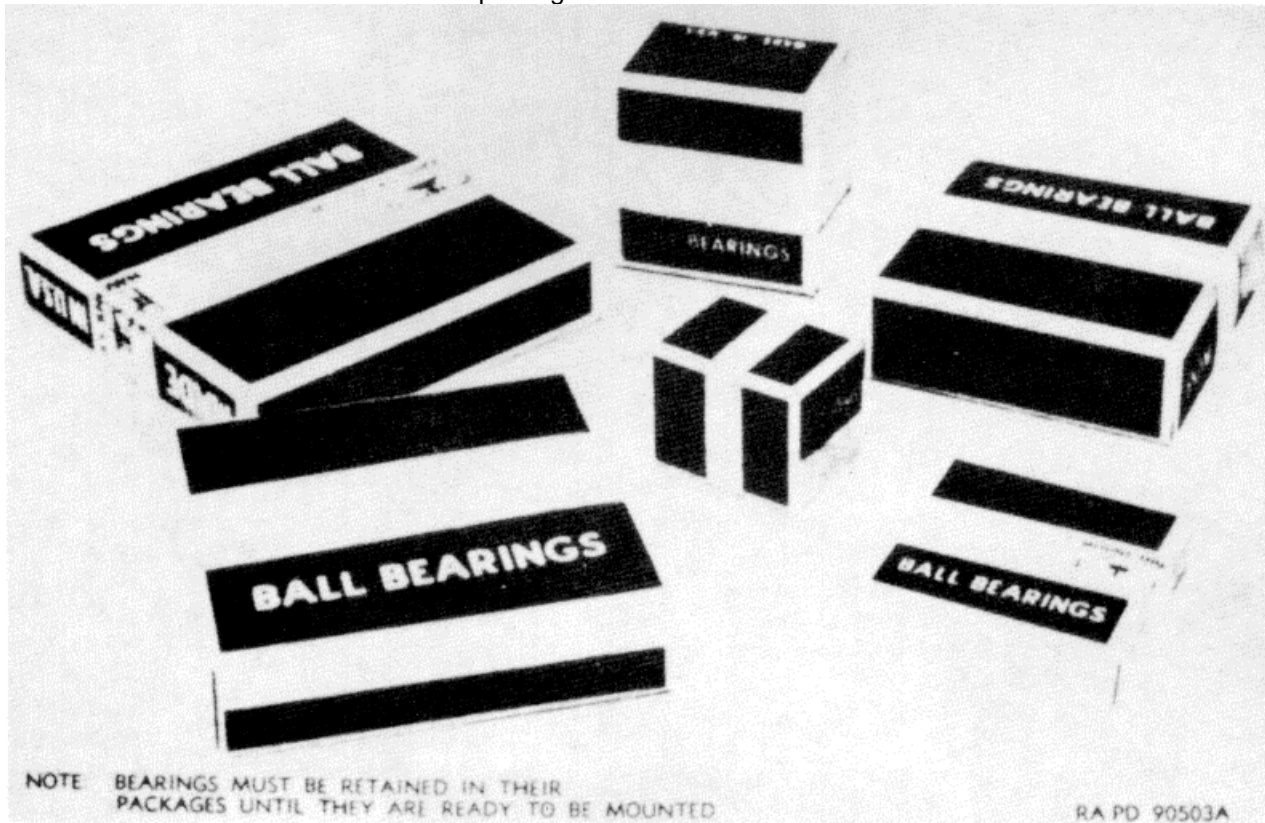

Figure 68. Cartonized bearings.

b. If a package is opened and the bearing is not immediately used, protect the bearing by rewrapping. The preservative coating of a new bearing must not be removed, unless inspection reveals the presence of dirt, in which case the bearing should be thoroughly cleaned, inspected, preserved, and repackaged.

c. New bearings must not be taken apart. They are correctly assembled when received. Rollers and races are matched. The position of the slit in some snapping bearings is important.

61. Shipment of Bearings

a. Domestic Shipment (Level B (AR 740 -15)).

- (1) Packaged bearings will be packed in domestic type wood-cleated fiberboard, wood-cleated plywood, nailed wood, wirebound, corrugated, or solid fiberboard boxes.
- (2) When possible, without wasting internal space, boxes will be of such size as to lend themselves to palletization on 40 by 48 pallets. Boxes will be permitted to overhang the pallet 1 1/2 inches on either side of the 40-inch width and 2 inches on

either side of the 48-inch dimension, with a height limitation of 48 inches exclusive of pallet.

b. Oversea Shipment (Level A (AR 740-15)).

- (1) Packaged bearings will be packed in oversea type wood-cleated fiberboard, wood-cleated plywood, nailed wood, wirebound, corrugated, or solid fiberboard boxes.
- (2) Each exterior wood container will have a waterproof case-liner fabricated in accordance with TM 9-1005, except when the unit or intermediate containers are boxes conforming to oversea-type corrugated and solid fiberboard.
- (3) Palletization for oversea shipment will conform to that prescribed for domestic shipment in a(2) above.
- (4) The gross weight for fiberboard boxes must not exceed 70 pounds and the gross weight for wooden boxes must not exceed 200 pounds.

APPENDIX

REFERENCES

1. Publication Indexes

The following indexes should be consulted frequently for latest changes or revisions of references given in this appendix and for new publications relating to materiel covered in this manual. Index of Army Motion Pictures, Film Strips, Slides, and Phono-Recordings DA Pam 103-1 Military Publications:

Index of Administrative Publications	DA Pam 310-1
Index of Blank Forms	DA Pam 310-2
Index of Graphic Training Aids and Devices	DA Pam 310-5
Index of Supply Manuals; Ordnance Corps.....	DA Pam 310-29
Index of Technical Manuals, Technical Bulletins, Supply Bulletins, Lubrication Orders, and Modification Work Orders	DA Pam 310-4
Index of Training Publications	DA Pam 310-3

2. Supply Manuals

a. General.

Introduction	ORD 1
FSC Group 31 Bearings: Class 3110 Bearings, Antifriction, Unmounted; 3130 Bearings, Mounted	SM 9-1-3110, 30 SM 9-1-3130
FSC Group 31 Bearings: Class 3120 Bearings, Plain, Unmounted	SM 9-1-3130
<i>b. Tools and Equipment.</i>	
Tools and Supplies for Field Maintenance Post, Camp, and Station Ordnance Shops	ORD 10 SNL N-20

3. Forms

DA Form 2028, Recommended Changes to DA Technical Manual Parts List or Supply Manual 7, 8, or 9 (Cut Sheet)	
DD Form 6, Report of Damaged or Improper Shipment	

4. Other Publications

a. General.

Inspection of Ordnance Materiel in Hands of Troops.....	TM 9-1100
Logistics (General): Unsatisfactory Equipment Report	AR 700-38
Military Symbols	FM 21-80
.....	AFM 55-3
Military Terms, Abbreviations, and Symbols:	
Authorized Abbreviations and Brevity Code	AR 320-50
Dictionary of United States Army Terms	AR 320-5
Military Training	FM 21-5
Ordnance Maintenance and General Supply in the Field.....	FM 9-10
Safety: Accident Reporting and Records.....	AR 385-40
Techniques of Military Instruction	FM 21-6
<i>b. Maintenance and Repair.</i>	
Antiaircraft Fire-Control System M88 Series: Cleaning and Lubrication of Motor Bearings	TB 9-6093-5/1
Instruction Guide: Ordnance Preservation, Packaging, Packing, Storage and Shipping	TM 9-1005
Issue of Supplies and Equipment: Preparation, Processing, and Documen- tation for Requisitioning, Shipping, and Receiving.....	AR 725-5

AGO 2737A

Marking and Packing of Supplies and Equipment: Marking of Oversea Supply	SP 746-30-5
.....	AFM 75-4
Marking and Packing of Supplies and Equipment: Shipment Digit Marking	SR 746-30-6
Ordnance Maintenance: Materials Used For Cleaning, Preserving, Abrading, and Cementing Ordnance Materiel, and Related Materials Including Chemicals, Lubricants, Indicators, and Hydraulic Fluids.....	TM 9-1007
Ordnance Operational List of Specifications and Instructions for Packaging and Processing General Supplies	SB 9-156
Painting Instructions for Field Use	TM 9-2851
Storage and Shipment of Supplies and Equipment: Preservation, Packaging, and Packing	AR 740-15
Supply Procedures	
List of Standard Lubricants, Hydraulic Fluids, Liquid Fuels, and Preservative Material Used by the Army	SB 38-5-3
Preservation, Packaging, and Packing Materials, Supplies and Equipment Used by the Army	SB 38-100
Vapor-Degreasing Equipment: Operation and Maintenance.....	TB ORD 584

AGO 2737A

INDEX

	Paragraphs	Pages		Paragraphs	Pages
Accidents, field reports	2c	2	Gaskets and shims	53	76
Adjusting devices	33	53	Grinding reliefs, cleaning	55	77
Adjustment, bearing:			Heating bearings:		
Auxiliary transmission	44	61	Installation	29	46
Devices	33	53	Removal by	13a	26
Differential	42e	61	Heavy duty-type bearings	8c	13
Fixtures for checking	45	61	Inspection and serviceability standards		
Front wheel	34	53	of bearings	21-24	35-40
Front wheel drive	35	53	Installation of bearings:		
Pinion	42b, c	61	Arbor press	26	43
Propeller shaft	40	58	Bearing pullers	27	43
Rear wheel	39	56	Driving	28	43
Spring seat	41	60	Final	31	49
Steering gear	38	56	Freezing	30	49
Steering knuckle pivot	37	56	Heating	29	46
Trailer axle	36	55	Instrument bearings:		
Transfer case	43	61	Lubrication:		
Worm cross shaft	42d	61	Air-driven gyro	51g	72
Aircraft type bearings	8d	13	Antiaircraft artillery wheel		
Authorized forms	2b	2	bearing	51h	74
Auxiliary equipment	52-57	76-77	Except open-type	51d	71
Auxiliary transmission bearing			Open type	51e	71
adjustment	44	61	Jack and Heintz bearings	51g	72
Ball bearing, description	4	5	Keys, splines, and grinding reliefs	55	77
Bearing:			Lubricant:		
Adjustment. (See Adjustment,			Choice	48	69
bearing.)			Cleanliness	49	70
Installation	25-31	41-49	Storage and segregation	50	70
Removal	9-14	14-27	Lubrication:		
Cam follower type bearings	8e	13	Correct	47	69
Cleaning bearings having seals or			General	46	69
shields	17	33	Instruction	51	70
Cleaning, drying, and demagnetizing			Materials	51b	70
bearings	15-20	30-34	Marking	59	78
Cleaning installed bearings	18	34	Marking, storage, and shipment of		
Cleanliness of lubricant	49	70	of new bearings	58-61	78-79
Closure of seals	52	76	Needle bearings:		
Cylindrical roller bearings, description ...	5	6	Description	8	10
Damage, common forms	22	35	Installation	25-31	41-49
Demagnetization of bearings	20	34	Removal	14	27
Description of antifriction bearings	3-8	3-10	Needle roller unassembled type	8f	13
Differential bearing adjustment	42e	61	Open bearings:		
Domestic shipment	61a	79	Cleaning	10	31
Drawn cup type bearings	8b	10	Lubrication	51c	71
Drying bearings	19	34	Oversea shipment	61b	79
Embossing (metal cans)	59c	78	Pinion, worm cross shaft, and -		
Equipment	52-57	76-77	differential bearing adjustment. (See		
Field reports of accidents	2c	2	Adjustment, bearing.)		
Final Inspection	23	38	Precautionary markings	59b	78
Fixtures for checking bearing			Precision bearings, lubrication	51e	71
adjustment	45	61	Propeller shaft bearing adjustment	40	58
Forms, records, and reports	2	2			
Front wheel bearing adjustment	34	53			
Front wheel drive bearing adjustment	35	53			

AGO 2737A

	Paragraphs	Pages
Rear wheel bearing adjustment	39	56
Removal of bearings:		
Arbor press	10	14
Bearing pullers	11	19
Driving	12	23
Heating, grinding, burning, or splitting	13	26
Roller bearings.....	5-7	6-9
Seals, closure.....	52	76
Self-aligning roller bearings, description	7	9
Serviceability standards	21-24	35-40
Shielded and sealed bearings, lubrication	51f	72
Shipment of bearings	61	79
Snaprings	56	77
Splines	55	77
Spring seat bearing adjustment	41	60
Sperry and Ternstedt bearings	51g	72
Steering gear bearing adjustment.....	38	56

	Paragraphs	Pages
Steering knuckle pivot bearing adjustment.	37	56
Storage and segregation of lubricants ..	50	70
Storage of bearings.	60	78
Table:		
Things to remember (table I)	15	30
Tapered roller bearing, description.	6	9
Torque:		
Adjustment of bearings	37a, b, 44b, 45a-e	56, 56, 61, 61,
.....		64
Device	45c	64
Spring scale	45d	64
Wrench.....	45e	64
Trailer axle bearing adjustment	36	55
Transfer case bearing adjustment	43	61
Types of needle bearings	8	10
Unsatisfactory equipment. ..	2d	2
Visual inspection.	24	40
Washers and cotter pins	57	77
Worm cross shaft bearing adjustment	42d	61

AGO 2737A

By Order of *Wilber M. Brucker*, Secretary of the Army:

L. L. LEMNITZER,
General, United States Army,
Chief of Staff.

Official:

R. V. LEE,
Major General, United States Army,
The Adjutant General.

Distribution:

Active Army:

USASA(2)	Savanna Ord Depot (5)
CNGB(1)	Sierra Ord Depot (3)
Tech Stf, DA (1) except	Sioux Ord Depot (2)
CofOrd (15)	Tooele Ord Depot (4)
Ord Bd (2)	Umatilla Ord Depot (3)
USCONARC (3)	Wingate Ord Depot (3)
US ARADCOM (2)	Ports of Emb (OS) (2)
US ARADCOM, Rgn (2)	Trans Terminal Comd (1)
OS Maj Comd (2) except	Army Terminals (1)
USAREUR (7)	OS Sup Agcy (1)
OS Base Comd (2)	Ord PG (10)
Log Comd (3)	Ord Arsenals (5) except
USA Ord Sp Wpn-Ammo Comd (6)	Benicia Arsenal (15)
MDW (1)	Frankford Arsenal (10)
Armies (3) except	Joliet Arsenal (4)
First US Army (5)	Lake City Arsenal (3)
Corps (2)	Radford Arsenal (1)
Div (2)	Raritan Arsenal (33)
Ord Gp (2)	Ravenna Arsenal (2)
Ord Bn (2)	Rock Island Arsenal (12)
Ord Co (2) except	Pantex Ord Plant (2)
9-12, 9-17, 9-22, 9-46, 9-47,	Springfield Armory (2)
9-57, 9-229, 9-347, 9-367,	Fld Comd, Def Atomic Spt Agcy (1)
9-376, 9-377 (none)	Mil Dist (1)
Fort Belvoir (5)	USA Corps (Res) (1)
Fort Bliss (9)	Sectors, USA Corps (Res) (1)
Fort Bragg (2)	Ord Proc Dist (1) except
Food Hood (7)	Chicago Ord Dist (none)
Fort Sam Houston (7)	Cleveland Ord Dist (2)
Fort Sill (6)	New York Ord Dist (5)
Br Svc Sch (2) except	Philadelphia Ord Dist (4)
USA Ord Sch (50)	St. Louis Ord Dist (3)
PMST Ord ROTC Units (1)	MAAG (1)
GENDEP (2)	Mil Msn (1)
Ord Sec, DENDEP (5)	JUSMAG (Greece) (2)
Ord Depots (10) except	JBUSMC (2)
Anniston Ord Depot (18)	Units org under fol TOE:
Black Hills Ord Depot (5)	29-55 (2)
San Jacinto Ord Depot (4)	

NG: State AG (3).

USAR: None.

For explanation of abbreviations used, see AR 320-50.

RECOMMENDED CHANGES TO EQUIPMENT TECHNICAL PUBLICATIONS



THEN... JOT DOWN THE DOPE ABOUT IT ON THIS FORM, CAREFULLY TEAR IT OUT, FOLD IT AND DROP IT IN THE MAIL!

SOMETHING WRONG WITH THIS PUBLICATION?

FROM: (PRINT YOUR UNIT'S COMPLETE ADDRESS)

DATE SENT

PUBLICATION NUMBER

PUBLICATION DATE

PUBLICATION TITLE

BE EXACT... PIN-POINT WHERE IT IS

PAGE NO.

PARA-GRAPH

FIGURE NO.

TABLE NO.

IN THIS SPACE TELL WHAT IS WRONG AND WHAT SHOULD BE DONE ABOUT IT:

TEAR ALONG PERFORATED LINE

PRINTED NAME, GRADE OR TITLE, AND TELEPHONE NUMBER

SIGN HERE:

DA FORM 2028-2
1 JUL 79

PREVIOUS EDITIONS ARE OBSOLETE.

P.S.—IF YOUR OUTFIT WANTS TO KNOW ABOUT YOUR RECOMMENDATION MAKE A CARBON COPY OF THIS AND GIVE IT TO YOUR HEADQUARTERS.

PIN: 026328-000